

# **USER'S GUIDE**

Installation & Operation  
Instructions

Level Indicating Transmitter  
Model LIT25  
Manual Series 3.3

Note: This page has been left blank intentionally.

## INDEX

Bench Test	4
Connections	4
Calibration System	6
Menu	7
Calibration Units Selection	8
4mA Calibration	9
Signal Relay	10
Damping	11
Echo Loss Response	11
Output Simulation	12
Store/Save Calibration	12
Temperature Indication	13
Enclosure Installation	14
Sensor Mounting	15
Error/Warning Messages	18
Troubleshooting	19
Fuse Replacement	21
Applications Hotline	22
Product Return Procedure	23
Warranty	24
Appendix A	25
Appendix B	30
Conversion Guide	31
Specifications	32

*IMPORTANT NOTE: This instrument is manufactured and calibrated to meet product specifications. Please read this manual carefully before installation and operation. Any unauthorized repairs or modifications may result in a suspension of the warranty.*

*Available in English*

*Available in Adobe Acrobat pdf format*

*Disponible en français*

*Disponible en español*

**QUICK BENCH TEST:**

Connect Sensor as shown below, then apply Power. When properly connected a soft clicking can be heard from the sensor and figures will show on the LCD display. Test operation of the LIT25 by holding the sensor steadily and aiming at a flat, stable target 12 to 28" (305 to 711 mm) away from the end of the sensor. Allow a few seconds for the LIT25 to lock onto the target before displaying its distance. The LIT25 will now display range in inches or cm.

Note: The LIT25 will not detect targets beyond the user entered maximum range.

**CONNECTIONS:**

**POWER INPUT:** The standard model requires AC power input between 100 to 130VAC 50/60Hz (1 amp fuse is recommended). No adjustments are necessary for any voltage in this range. Option EI (nominal 220VAC) requires power input between 200-250VAC 50/60Hz. (See OPTIONS section of this manual for connection of optional 24VDC power input).

**IMPORTANT NOTE:** To comply with CSA/NRTL standards, AC power input and relay connection wires must have a water tight fitting conduit entry to the instrument enclosure.

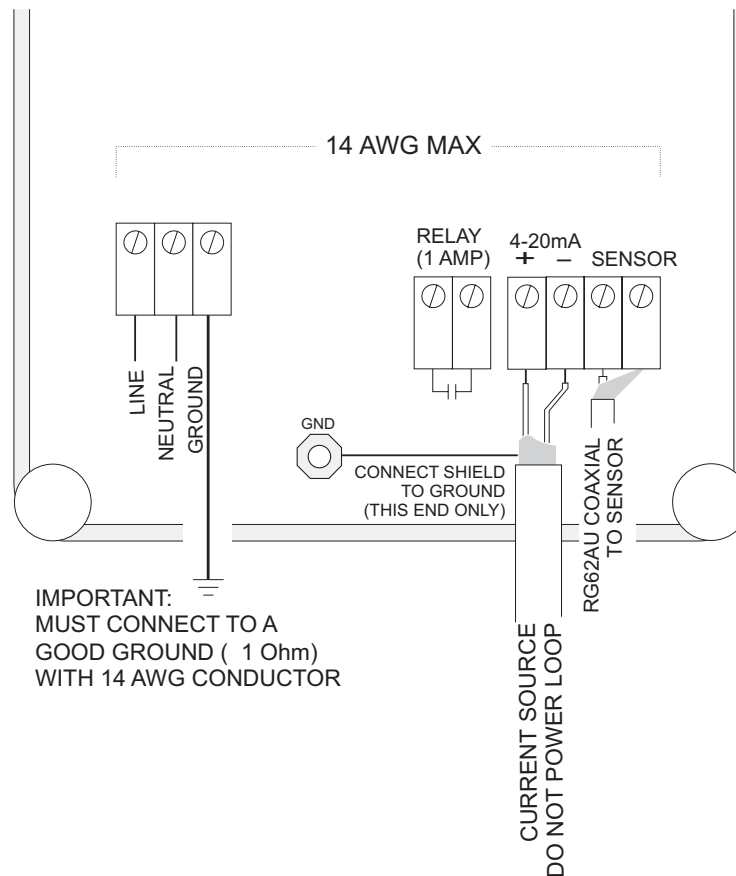

**RECOMMENDED CONDUIT ENTRY**

Use a screwdriver to "knock-out" conduit entry points at bottom of enclosure.

Use one entry for power input and relay wires. Use separate entry for 4-20mA and sensor cable.

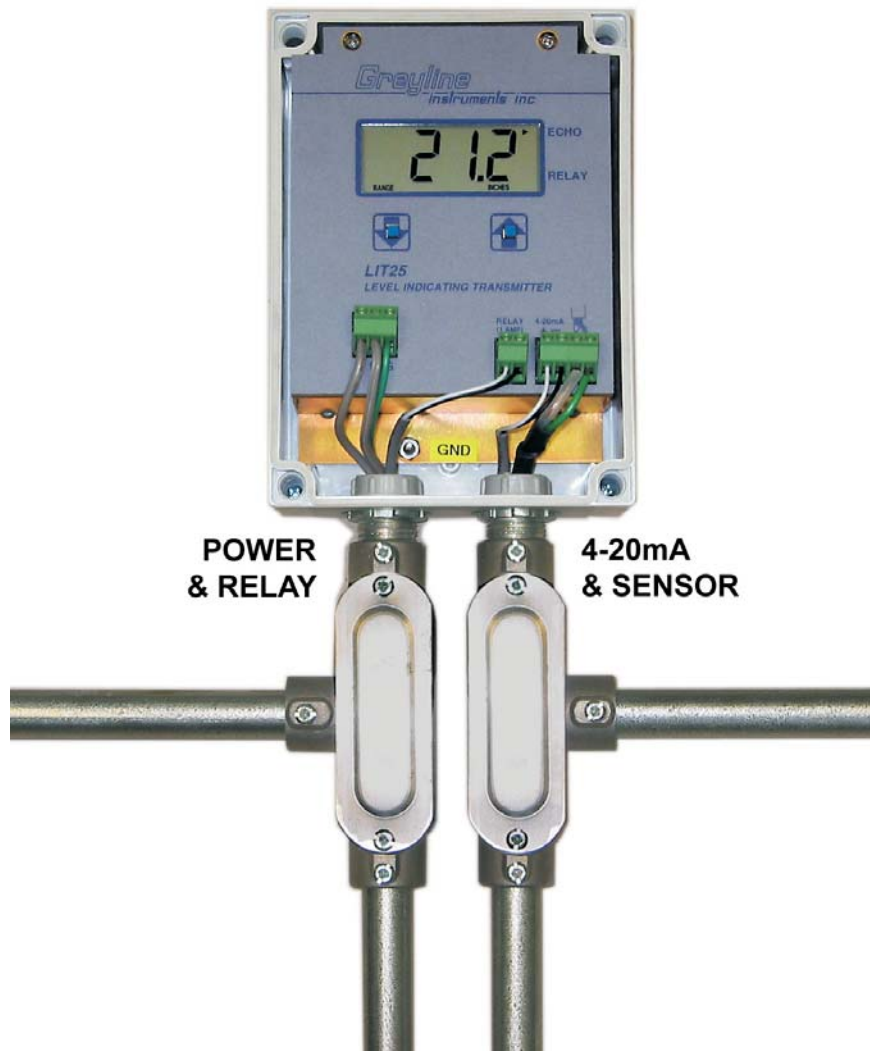

**KEYPAD SYSTEM**

The LIT25 has a simple 2-key calibration system. Operating and calibration modes are shown on the 4-digit display. The keys are used to calibrate the LIT25, and to view operating mode and functions. If the keys are not used for 10 minutes, the LIT25 will automatically go to **NORMAL MODE**. Except in **OUTPUT SIMULATION** mode, the Relay and 4-20mA output are not affected by use of the keys until your calibration is stored.

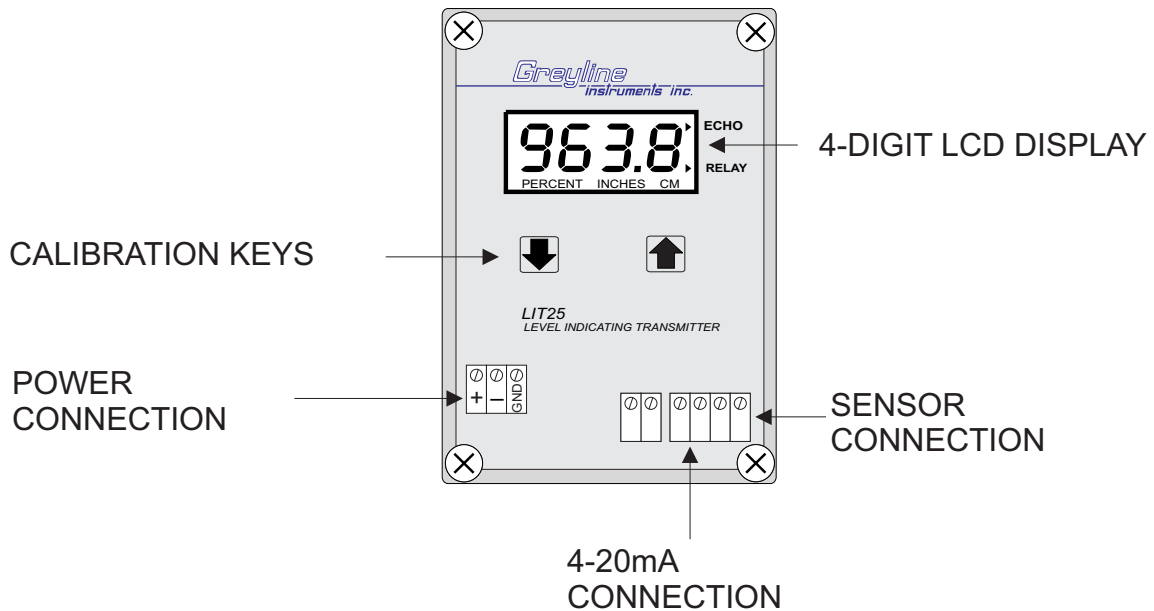

**MENU - FLOW CHART**

The following diagram shows the LIT25 Menu system. Arrows show the directions to leave a box. Pressing a corresponding key will move to the next box in the direction shown. Numeric values are changed by pressing and holding the **↑** or **↓** keys.

At the bottom of the Menu is a YES? prompt. To store the calibration values permanently (even through power failure), press the **↑** key. If the **↓** key is pressed from the YES? prompt no changes will be stored and the system will return to **NORMAL** mode.

**MENU**

See Page #

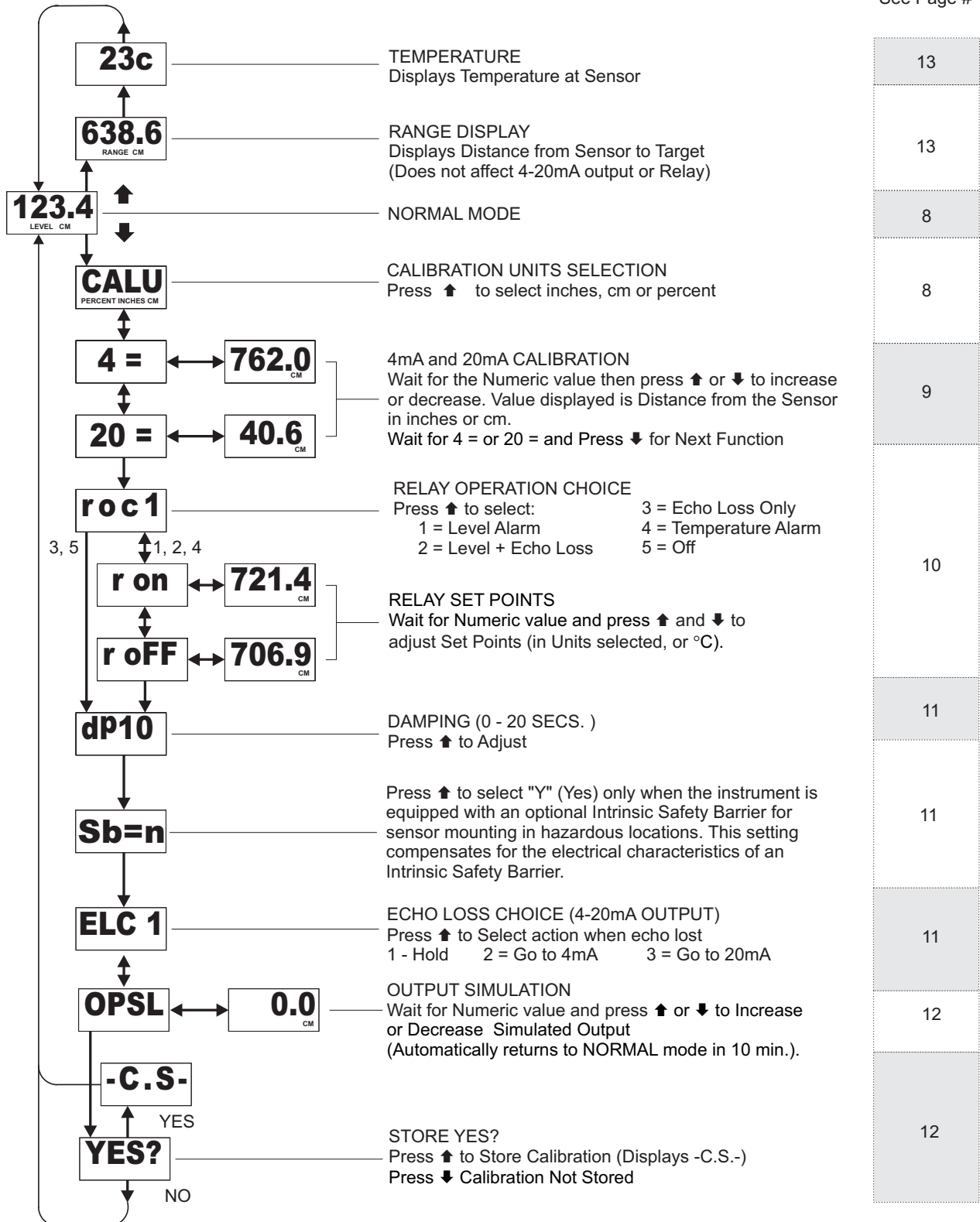

**NORMAL MODE**

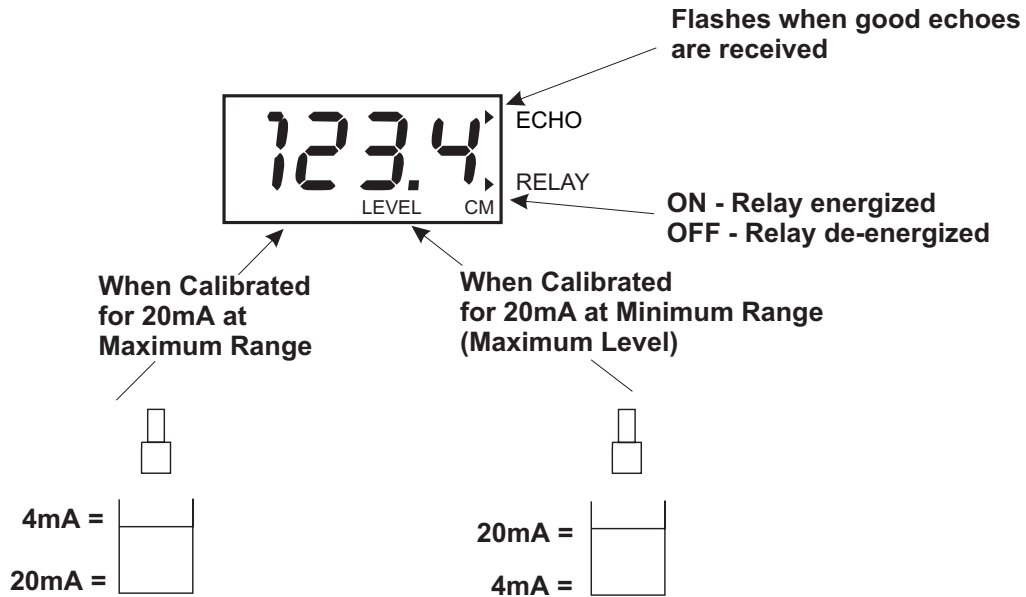

**CALIBRATION UNITS SELECTION**

Press **↓** from NORMAL mode, Display will show:

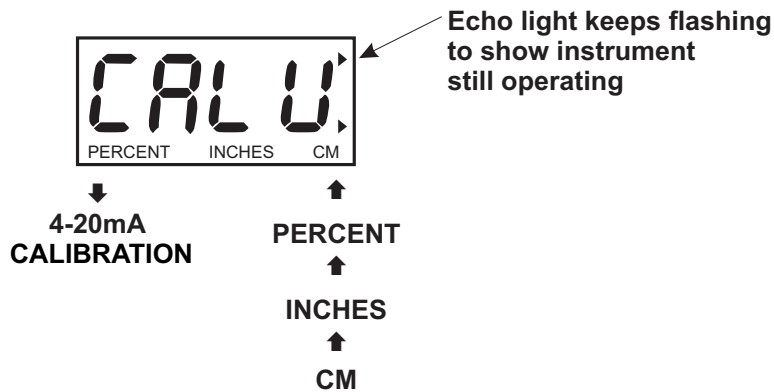



**4mA CALIBRATION**

The Display will alternate between  and  every 3 seconds.

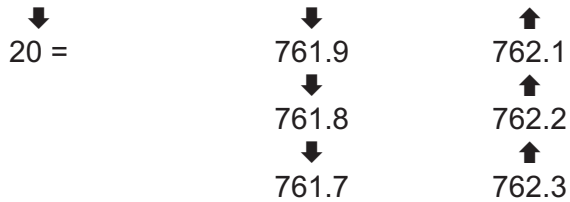

MAXIMUM VALUES: 600 inches / 1524 cm  
 MINIMUM VALUES: 8 inches / 20.3 cm (depending on sensor model)  
 MINIMUM SPAN (distance between 4= and 20=): 2" (5 cm)

**20mA CALIBRATION**

Wait for 4 = and press ↓ to display 20 =. Now follow the same procedure to calibrate the distance from the Sensor for 20mA output.

Remember that the LIT25 automatically reads LEVEL if 20 = is set to the *minimum* distance from the sensor. Calibrate in RANGE mode by setting 20= to the *maximum* distance from the sensor.

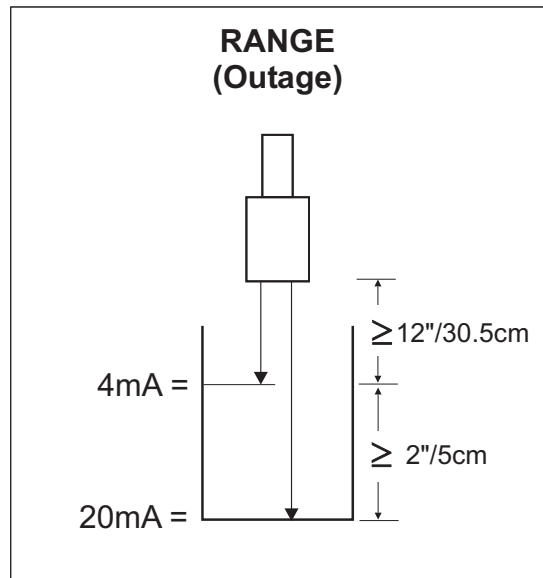
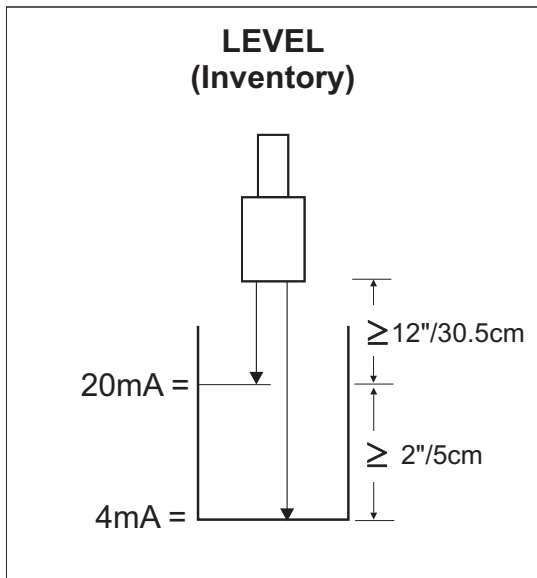

**SIGNAL RELAY**

The LIT25 Relay is rated 1ampere, 24VDC, 120/240VAC. It includes an internally connected noise suppressor or “snubber” with 25K ohms impedance. Very low AC electrical loads may appear to “leak” current. Maximum leakage is:

- 10mA @ 110VAC
- 20mA @ 220VAC

No leakage will be measured with DC electrical loads.

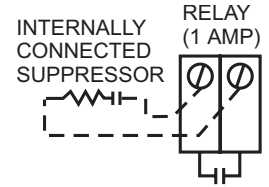

**RELAY OPERATION CHOICE**

The LIT25’s Signal Relay can be configured to operate as:

- ROC1** = Level Alarm
- ROC2** = Level + Echo Loss Alarm
- ROC3** = Echo Loss only Alarm
- ROC4** = Temperature Alarm (measured at the Sensor)
- ROC5** = OFF (de-energize) at all times

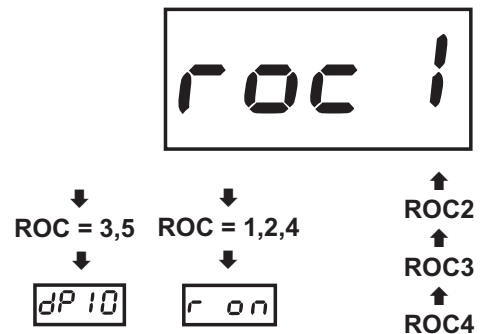

Press **↑** to select the **ROC**.

**RELAY CALIBRATION**

**ROC1** (Level Alarm)

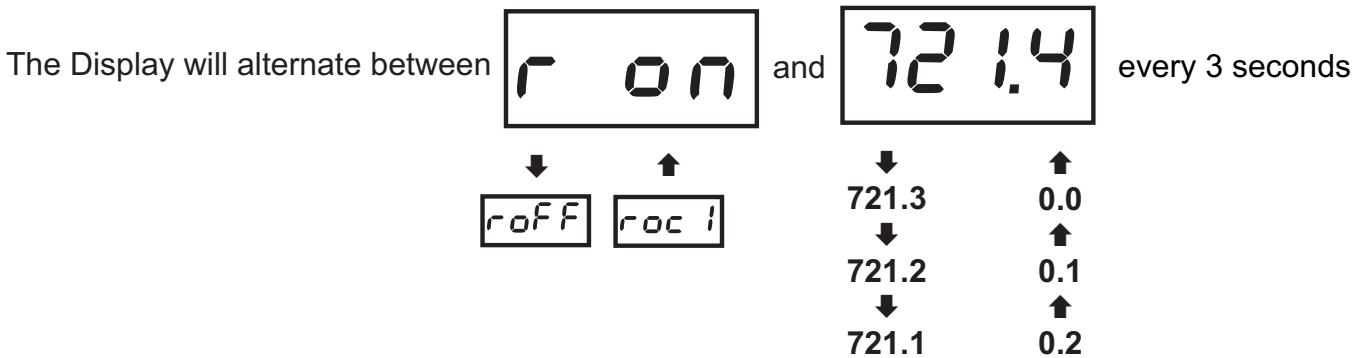

**ROC2** (Level + Echo Loss Alarm) - Relay will be energized when the Relay ON set point is reached.  
or if the echo is lost (no echoes for more than 20 seconds).

**ROC4** (Temperature Alarm) - Minimum Set Point -40°C (= -40°F)  
- Maximum Set Point 100°C (= 212°F)

NOTE: The Set Points are displayed in the units selected at **CALU**. Two different Set Points (**RON** and **ROFF**) allows a Relay “deadband” for Pump Control and to avoid Relay chatter.

Example of Relay Calibration

Span (Max Level) = 184 inches

**RON** in inches = **150**

**ROFF** in inches = **30**

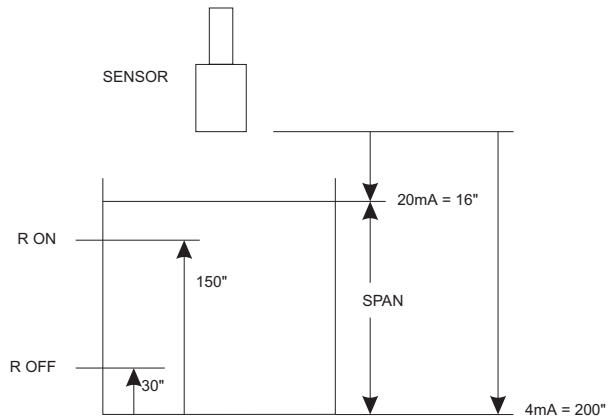

**DAMPING**

Normal Setting: **DP10**

Fast Response (up to 1/2 inch /13 mm level change per second): **DP5** or less

Slow Response (turbulence) **DP15** or more

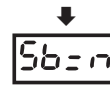

↑ DP11  
↑ DP12

**20 SECS.  
MAXIMUM**

NOTE: Damping Time (in seconds) is the response time to indicate a new target. Longer Damping Times also reject false targets like agitators, splashing etc.

**INTRINSIC SAFETY BARRIER**

Press ↑ to select "Y" (Yes) only when the instrument is equipped with an optional Intrinsic Safety Barrier for sensor mounting in hazardous locations. This setting compensates for the electrical characteristics of an Intrinsic Safety Barrier.



↑ Y

**ECHO LOSS RESPONSE**

If no echoes are received for 20 seconds or longer the 4-20mA output can be programmed to respond as follows:

- ELC1** = Hold last reading
- ELC2** = Output 4mA
- ELC3** = Output 20mA



↑ ELC2  
↑ ELC3

When one valid echo is received the LIT25 will resume normal operation.

**OUTPUT SIMULATION MODE**

The Display will alternate between

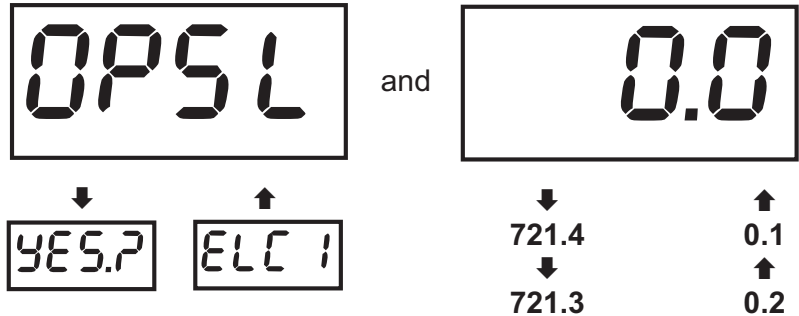

The Output Simulation function controls the digital display 4-20mA output and control relay. Use it to simplify calibration of remote 4-20mA devices such as chart recorders or remote displays, and to test relay set-points.

Press **↑** and **↓** to simulate levels from 0% to 100% of your calibrated span. Increments will automatically accelerate when **↑** or **↓** is continuously pressed.

**TO STORE (SAVE) CALIBRATION**

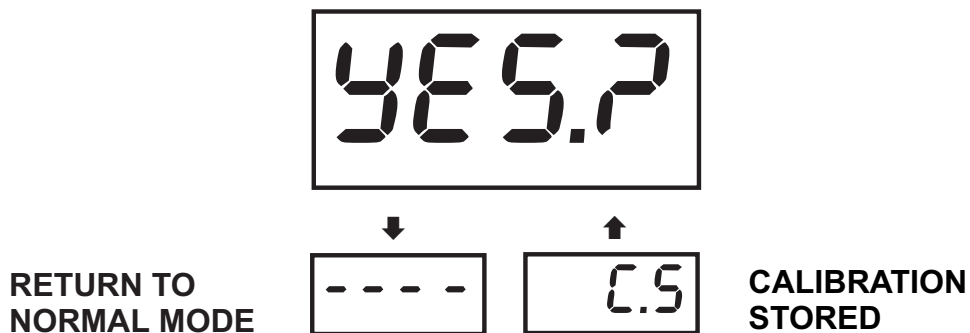

Press **↑** to Store calibration (LIT will display **-C.S-**). Calibration is stored in non-volatile memory (even through power interruptions).

Press **↓** to return to NORMAL mode *without* storing any changes.

**RANGE DISPLAY**

From Normal Mode press **↑**  
Displays distance from the Sensor to Target.  
Use to check measurements during calibration.

(RANGE and UNITS flash.)

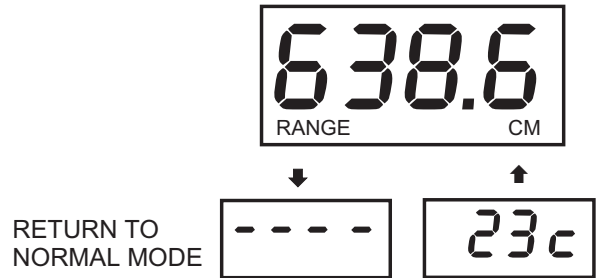

Note: The LIT25 will not detect targets beyond the user entered maximum range.

**TEMPERATURE DISPLAY**

Displays temperature in degrees Centigrade  
measured at the Sensor.



**TEMPERATURE LOG**

Displays maximum temperature in degrees  
Centigrade measured at the Sensor.



From normal Temperature display, press and hold **↓** then **↑**.

## ENCLOSURE INSTALLATION

Locate the enclosure within 500 ft (150 m) of the sensor. It can be wall mounted with four mounting screws (supplied) or panel mounted with Option PM Panel Mounting Kit from Greyline Instruments. Avoid mounting the enclosure in direct sunlight to protect the electronics from damage due to overheating and condensation. Seal conduit entries to prevent moisture from entering enclosure.

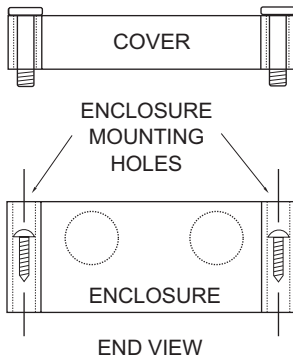

### NEMA4X (IP66) WITH CLEAR COVER

1. Remove enclosure cover.
2. Insert #6 screws through the four enclosure mounting holes to secure enclosure to wall or mounting stand.
3. Replace Cover

An additional conduit hole can be cut in the end of the enclosure if required. Use a hole saw or Greenlee-type hole cutter to make additional holes.

#### Note:

1. This non-metallic enclosure does not automatically provide grounding between conduit connections. Grounding must be provided as part of the installation. Ground in accordance with the requirements of the National Electrical Code. System grounding is provided by connecting grounding wires from all conduit entries to the steel mounting plate or another point which provides continuity.
2. Water tight “O” ring seals must be used if cable strain-reliefs are used.

### SENSOR MOUNTING LOCATION

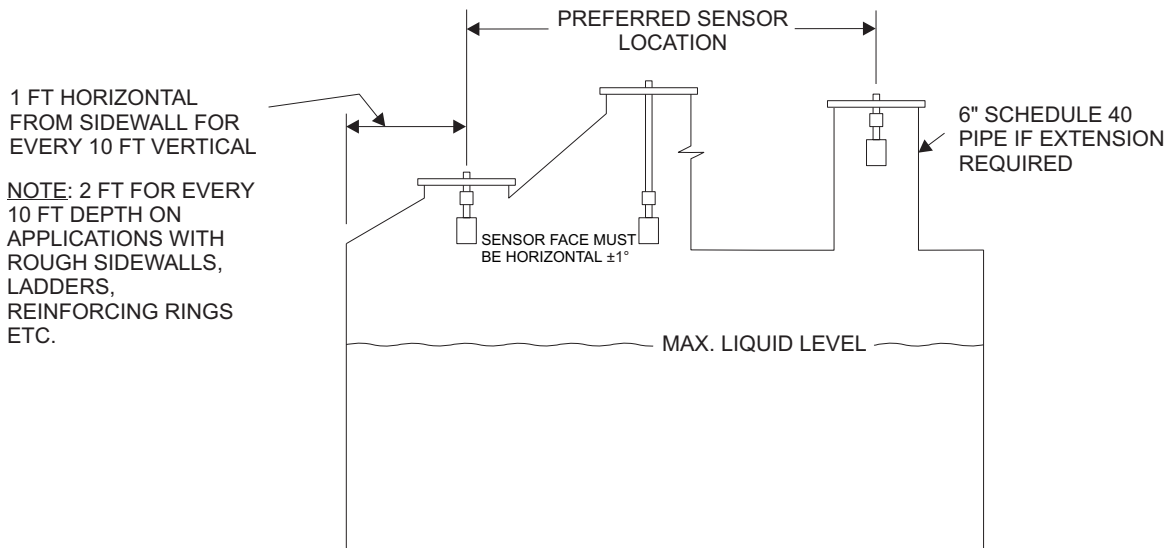

### SENSOR MOUNTING

Each sensor is equipped with a  $\frac{3}{4}$  inch “isolation coupling” which **MUST** be used in your installation. A threaded nipple or length of conduit may be used to position the sensor at the desired height.

The sensor should be hand-tightened (like a light bulb) by turning the sensor stem only. **DO NOT** use a wrench and do not over tighten. **DO NOT** clamp the sensor below the isolation coupling.

The standard PZ32T Sensor must be mounted 12" / 30.48 cm or more above the maximum liquid level. (Optional PZ12 sensor must be 8" / 20.3 cm above maximum level and optional PZ52T sensor must be 16" / 406 mm above maximum level.)

**SENSOR MOUNTING**

Notes:

1. Use the 3/4" NPT "Isolation Coupling" supplied and *hand tighten* only. Do not clamp sensor body or stem.
2. Locate the sensor 1 ft (30 cm) from the sidewall or obstruction for every 10 ft (3 m) depth.
3. Do *not* mount in direct sunlight.
4. Extend sensor cable up to 500 ft (150 m) with RG62AU coaxial only.

**FLANGE MOUNT**

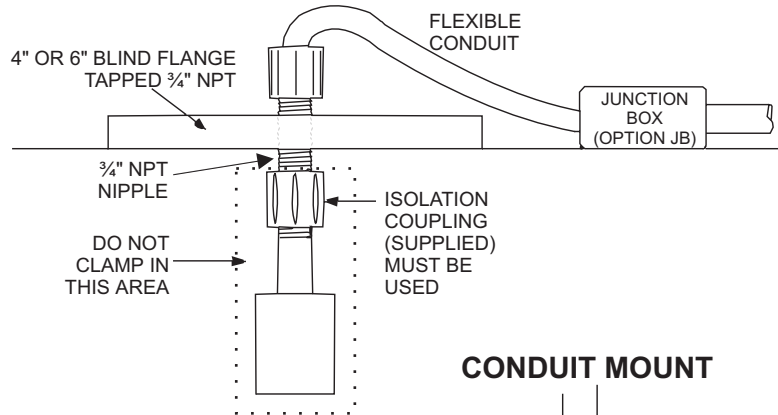

**CROSS BAR MOUNT**

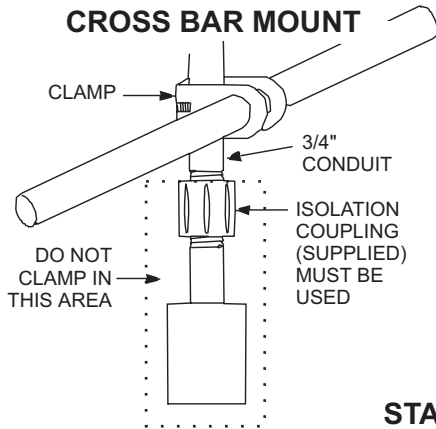

**CONDUIT MOUNT**

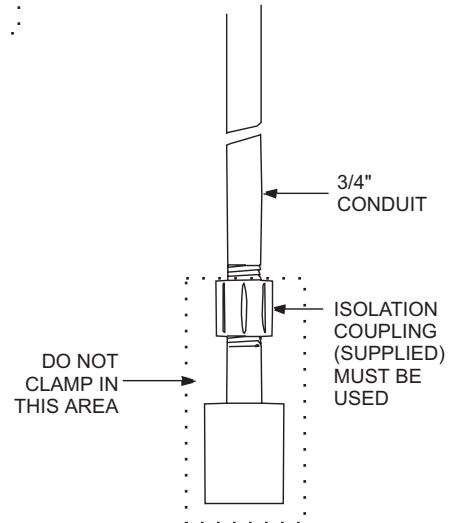

**STAND PIPE MOUNT**

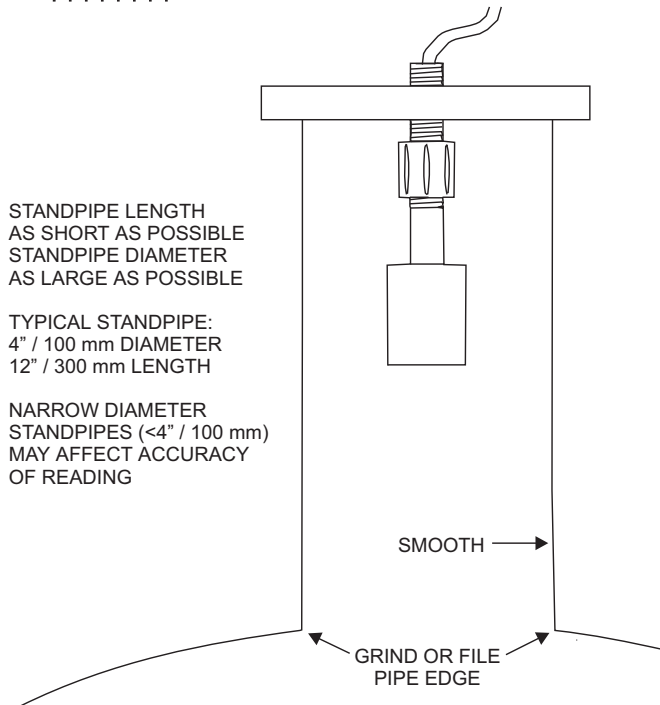

**ANGLE MOUNT**

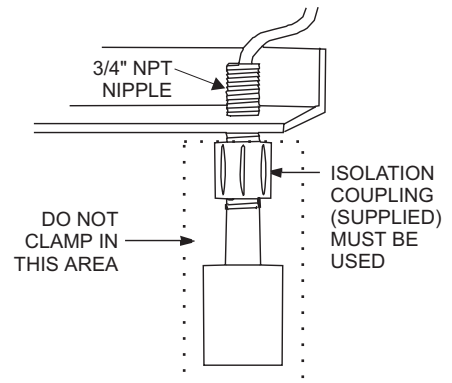



**SENSOR MOUNTING/LOCATION**  
**- Tank Level/Inventory Applications**

Each LIT25 Level Transmitter includes a non-contacting ultrasonic sensor. The sensor must be installed in a position to obtain unobstructed echoes from the liquid or material being measured.

Mount the sensor away from pipes, ladders, or structural members which might cause continuous false echoes.

**BAD**

**GOOD**

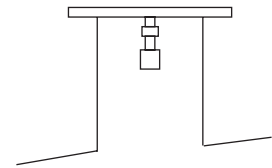
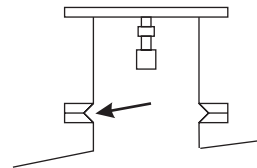
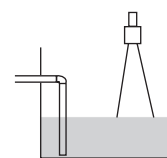
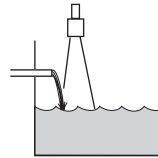
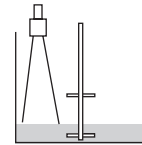
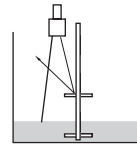
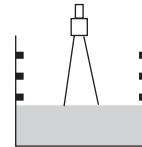
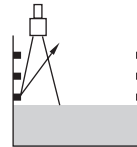
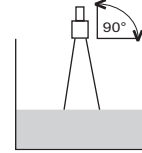
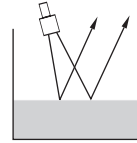

**SOLIDS AND POWDERS**

SENSOR MOUNTED AWAY FROM MATERIAL PATH. COARSE SOLIDS WILL USUALLY RETURN AN ECHO EVEN IF AT AN ANGLE

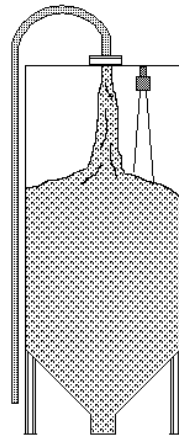

FINE POWDERS MAY NEED SENSOR TILTED NORMAL TO SURFACE TO OBTAIN GOOD ECHOES

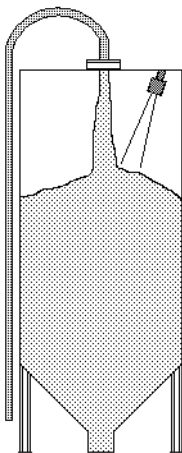

**ERROR/WARNING MESSAGES**

**SEnS** ↔ **OPEn** Instrument has detected Sensor connections/cable open.

**SEnS** ↔ **SHrT** Instrument has detected Sensor connections/cable short.

**no** ↔ **ECHO** No valid echoes for 10 seconds.

**ECHO** ↔ **LOSS** No valid echoes for 20 seconds. See Troubleshooting (F).

**Err.** → **bAd** → **SPAn** Illegal Span. Distance between 20 = and 4 = must be greater than 2" (5 cm)

**Err.** → **ECHO** → **Too** → **CLOS** Indicates that the target is above the calibrated maximum level (too close to the Sensor).

**-or-** Indicates target is further than the calibrated Maximum Range.

**EEEE** Indicates that the LIT25 has experienced electrical interference strong enough to corrupt the memory. The LIT25 must be reset and recalibrated.  
Reset Procedure 1: Reset will clear all memory. LIT25 will need recalibration after this procedure: Press and hold **▲** and **▼** until the LIT25 displays - - - -.

**SFX.X** Always displayed at power-up (x.x indicates Software version).  
Otherwise indicates instrument has reset automatically. See Troubleshooting (C,D,E).

**FIELD TROUBLESHOOTING**

<u>SYMPTOMS</u>	<u>CHECK</u>
Level Display - full scale	A
- zero	B
- erratic - random	C
- higher than actual	D
- fluctuating	E
<b>ECHO LOSS</b> prompt - flashing	F
Calibration Non-Linear	H
<b>EEEE</b> - memory corruption	I

SYMPTOMS      FAULTS

*Unit "See's Wrong Target Due To:*

A	- sensor cover not removed
A,C,D,F	- sensor not aimed correctly
A,D,F	- dust/dirt buildup on sensor
A,D,F	- condensation on sensor
A,D	- sensor mounting stand pipe - too long/ - too narrow - dirty/ - gasket intruding
D,E	- agitator, strong turbulence
C	- material filling through sensor beam

*Unit Picks-Up Acoustic Interference Due To:*

A,C	- noise from high pressure fill
A,D	- sensor coupling over tightened
A,D	- sensor coupling not used
C	- other ultrasonic sensor in close proximity

*Electrical Interference:*

C	- sensor cable connections reversed
C,D	- through Sensor cable
C	- sensor cable and/or junction not insulated
C,D	- through 4-20mA output cable

SOLUTIONS

- remove protective cover after installation
- clean *carefully* (do not scratch sensor face)
- lower sensor
- insulate sensor mounting location
- wipe sensor face and body with Rain-X
- lower Sensor below stand pipe intrusion
- increase Damping
- increase Damping
- install submerged fill pipe
- hand tighten only (like a light bulb)
- use isolation coupling supplied
- separate Sensors
- use properly *grounded* metal conduit
- use metal Junction Box
- use shield twisted pair (shield to AC ground)

<u>SYMPTOMS</u>	<u>FAULTS</u>	<u>SOLUTIONS</u>
C,D	- wiring or installation close to variable speed drive or inverter	- follow VSD manufacturer's instructions for Drive grounding wiring and shielding
C,D,E	- AC/Chassis Ground missing on instrument power connections	- install adequate Ground
I	- relay sparking produces EMI interference	- use snubber across Relay contacts (option SNUB) - do not exceed 1 ampere load
I	- instrument installed in the same panel with high voltage/large motor controls	- relocate or use metal enclosure
<i>Wiring Problems Due to Sensor Cable:</i>		
C,F	- open circuit	- check connections/continuity (8850 to 12700 ohms max./-30°C to +70°C )
F	- short circuit	- check connections/continuity (8850 ohms min.)
F	- too long (max. 500 ft, 150 m)	
C	- bundled/run in conduit with power cable	
C	- sensor ground shorted to conduit/enclosure	- insulate
A	- extended with wrong type of wire	- use only RG62AU coaxial
C	- close to high voltage/large motors	
<i>Non-Linearity Due To:</i>		
H	- vapour	- calibrate in-situ
B,H	- zero not set accurately	- recalibrate
H	- full scale not set accurately	- Note: Minimum Range must be $\geq 12''$ (30.5cm)

**FUSE REPLACEMENT**

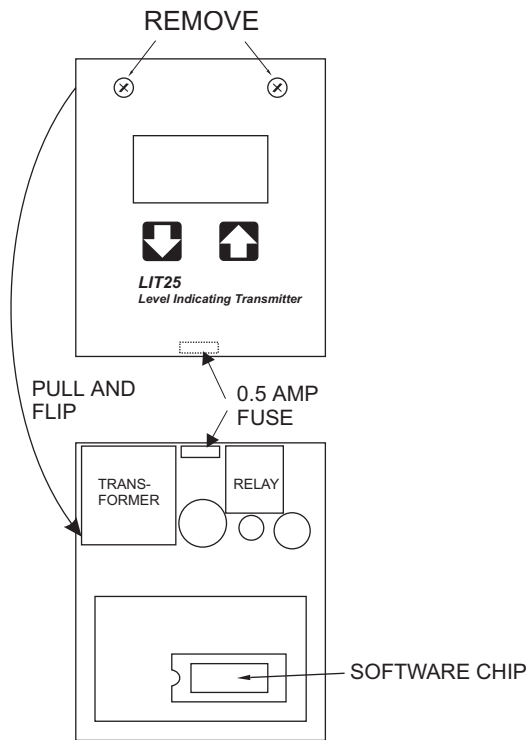

1. Disconnect Power
2. Remove 2 top screws
3. Pull and flip chassis
4. Remove 0.5 amp fuse with long nose pliers
5. Install new fuse (Replacement Greyline Part #1/2 Amp PCC)

**APPLICATIONS HOTLINE**

For applications assistance, advice or information on any Greyline Instrument contact your Sales Representative, write to Greyline or phone the Applications Hotline below:

United States:	Tel: 315-788-9500	Fax: 315-764-0419
Canada:	Tel: 613-938-8956	Fax: 613-938-4857
Toll Free:	888-473-9546	
Email:	<a href="mailto:info@greyline.com">info@greyline.com</a>	
Web Site:	<a href="http://www.greyline.com">www.greyline.com</a>	

Greyline Instruments Inc.

Canada  
16456 Sixsmith Drive  
Long Sault, Ont. K0C 1P0

USA:  
105 Water Street  
Massena, NY 13662

## **PRODUCT RETURN PROCEDURE**

Instruments may be returned to Greyline for service or warranty repair.

### **1 Obtain an RMA Number from Greyline -**

Before shipping a product to the factory please contact Greyline by telephone, fax or email to obtain an RMA number (Returned Merchandise Authorization). This ensures fast service and correct billing or credit.

When you contact Greyline please have the following information available:

1. Model number / Software Version
2. Serial number
3. Date of Purchase
4. Reason for return (description of fault or modification required)
5. Your name, company name, address and phone number

### **2 Clean the Sensor/Product -**

***Important: unclean products will not be serviced and will be returned to the sender at their expense.***

1. Rinse sensor and cable to remove debris.
2. If the sensor has been exposed to sewage, immerse both sensor and cable in a solution of 1 part household bleach (Javex, Clorox etc.) to 20 parts water for 5 minutes. Important: do not immerse open end of sensor cable.
3. Dry with paper towels and pack sensor and cable in a sealed plastic bag.
4. Wipe the outside of the enclosure to remove dirt or deposits.
5. Return to Greyline for service.

### **3 Ship to Greyline -**

After obtaining an RMA number please ship the product to the appropriate address below:

*Canadian and International  
Customers:*

Greyline Instruments Inc.  
16456 Sixsmith Drive  
Long Sault, Ont. K0C 1P0

RMA#

*USA  
Customers:*

Greyline Instruments Inc.  
105 Water Street  
Massena, NY 13662

RMA#

## LIMITED WARRANTY

Greyline Instruments warrants, to the original purchaser, its products to be free from defects in material and workmanship for a period of one year from date of invoice. Greyline will replace or repair, free of charge, any Greyline product if it has been proven to be defective within the warranty period. This warranty does not cover any expenses incurred in the removal and re-installation of the product.

If a product manufactured by Greyline should prove defective within the first year, return it freight prepaid to Greyline Instruments along with a copy of your invoice.

This warranty does not cover damages due to improper installation or handling, acts of nature, or unauthorized service. Modifications to or tampering with any part shall void this warranty. This warranty does not cover any equipment used in connection with the product or consequential damages due to a defect in the product.

All implied warranties are limited to the duration of this warranty. This is the complete warranty by Greyline and no other warranty is valid against Greyline. Some states do not allow limitations on how long an implied warranty lasts or limitation of incidental or consequential damages, so the above limitations or exclusions may not apply to you.

This warranty gives you specific legal rights, and you may also have other rights which vary from state to state.

Greyline Instruments Inc.



**APPENDIX A - OPTIONS and ACCESSORIES**

- XC - Extra Sensor Cable up to 500 ft (152 m) length
- JB - Sensor Cable Junction Box
- ISB - Intrinsic Safety Barrier for Sensor and Cable installation in hazardous-rated locations (factory-installed option/larger enclosure used)
- 24VDC - 24VDC Power Input (factory-installed option)
- 12VDC - 12VDC Power Input (factory-installed option)
- PM2 - Enclosure Panel Mount

**EXTRA SENSOR CABLE  
(ACCESSORY XC)**

Each Greyline LIT25 includes 25 ft. (7.6 m) or 50 ft. (15 m) continuous RG62AU coaxial Sensor Cable. Additional RG62AU coaxial cable and Cable Junction Box (Option JB) may be spliced and extended up to 500 ft (152 m) as required during installation. No adjustment is required when the sensor cable is extended or shortened. Use only RG62AU (or RG62U) coaxial cable which is available from Greyline Instruments or your local distributor. Nominal impedance of RG62AU cable is 93 ohms.

Extended sensor cable must be installed in metal conduit to prevent interference. Do not use BNC coaxial connectors (TV cable type). Recommended installation with a metal junction box is illustrated below:

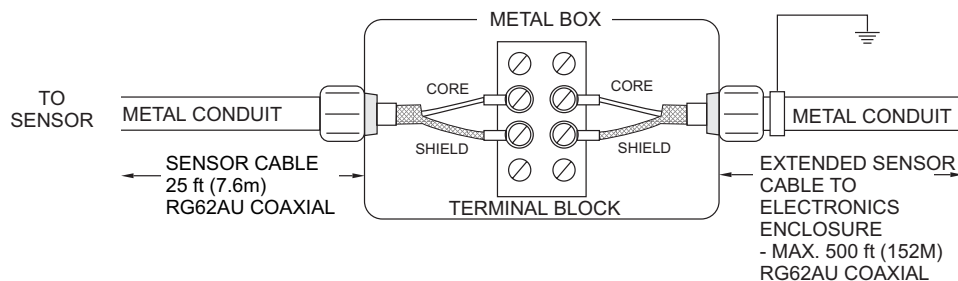

**SENSOR CABLE JUNCTION BOX  
(ACCESSORY JB)**

**DIMENSIONS  
OPTION JB - JUNCTION BOX**

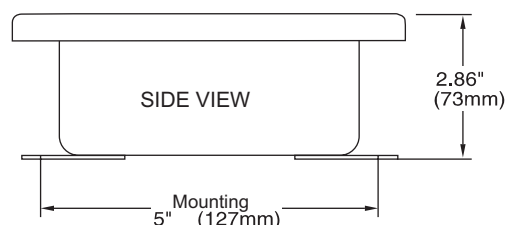
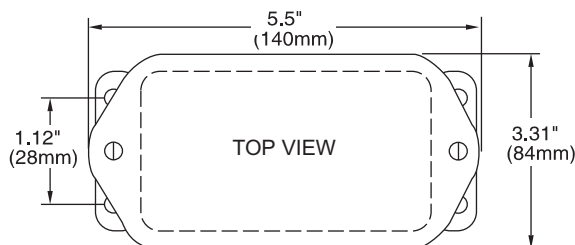

**SENSOR INTRINSIC SAFETY - OPTION ISB**

SENSOR MODELS PZ32T-A/PZ32TE-A (with built-in temperature compensation)

When connected through an Intrinsic Safety Barrier, the Greyline PZ32T-A and PZ32TE-A sensors are CSA certified for installation in a hazardous location rated:

- Class I, Groups C,D
- Class II, Groups E,F and G
- Class III

Intrinsic Safety Barriers may be ordered with the Greyline instrument and are supplied mounted in the Greyline instrument enclosure. A larger enclosure is used.

Replacement barrier fuses (Part No. ISB-011239) may be purchased separately. Barriers must be installed in the sensor cable between the safe and hazardous locations, and must be mounted in either the safe or Div.2 area. Barriers may be plate, busbar or rail mounted.

Intrinsic Safety Barrier Specifications: Certified, rated 17.5V max, 95 ohms min.(Recommended: Stahl Model 9001/02-175-200-10)

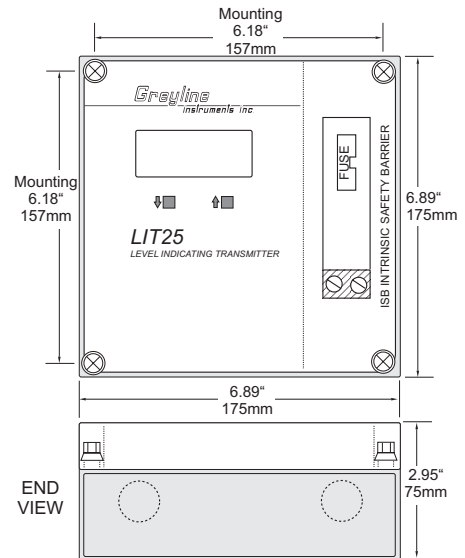

**CONNECTIONS (Stahl Model 9001/02-175-200-10)**

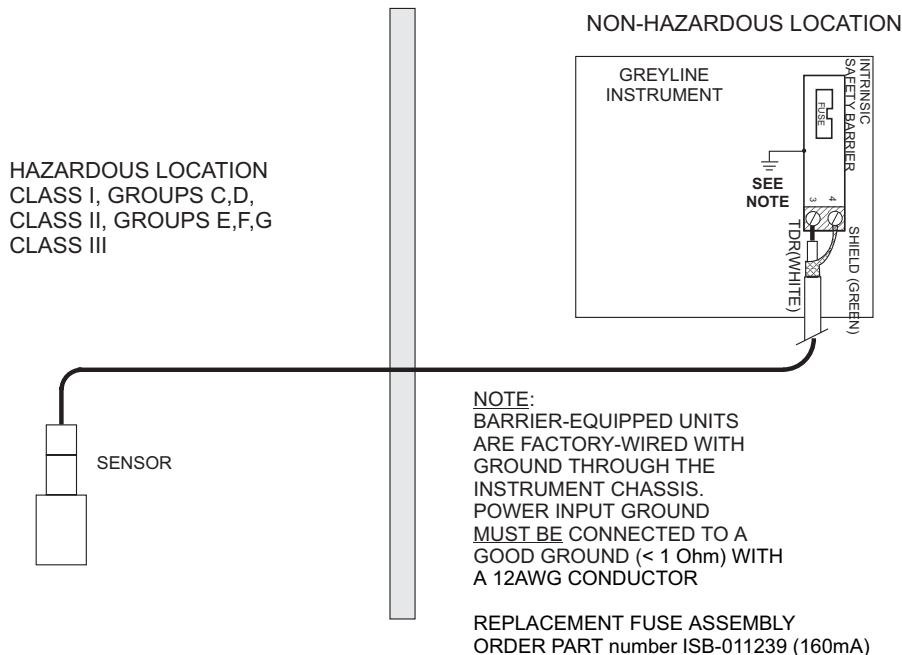

**24VDC POWER INPUT OPTION**

LIT25 Level Indicating Transmitters may be ordered factory-configured for 24VDC power input.

**12VDC POWER INPUT OPTION**

LIT25 Level Indicating Transmitters may be ordered factory-configured for 12VDC power input.

**QUICK BENCH TEST:**

Connect Sensor as shown below, then Power. When properly connected a soft clicking can be heard from the sensor and figures will show on the LCD display. Test operation of the LIT25 by holding the sensor steadily and aiming at a flat, stable target 12 to 28" (305 to 711 mm) away from the end of the sensor. Allow a few seconds for the LIT25 to lock onto the target before displaying its distance. The LIT25 will now display Range (Distance) in inches or cm.

**CONNECTIONS:**

POWER INPUT: Connect only 24VDC/0.5 Amps (or 12VDC) to the + and – terminals. The Power Input GND must be connected to the nearest good Ground pole. Power Consumption is 4.32 W continuous.

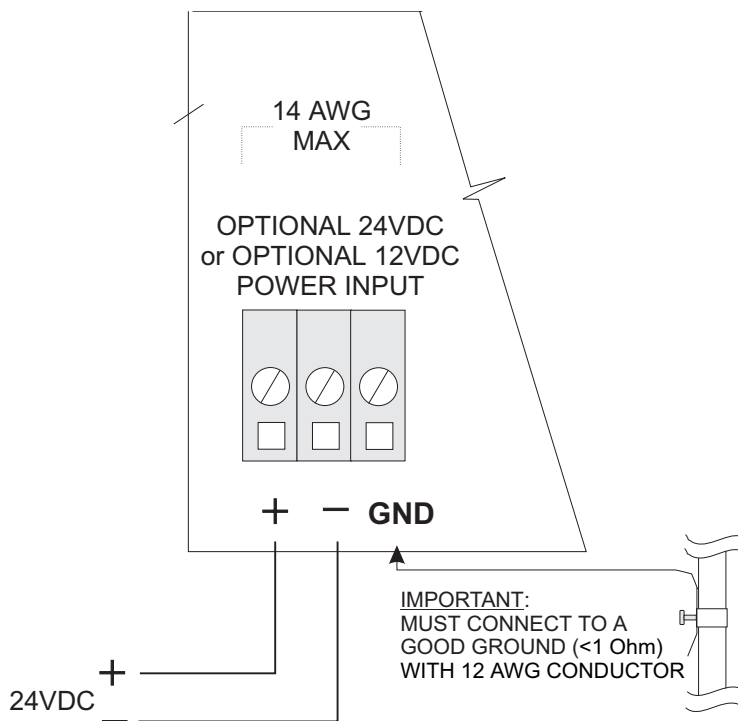

**Option PM2 Enclosure Panel Mount**

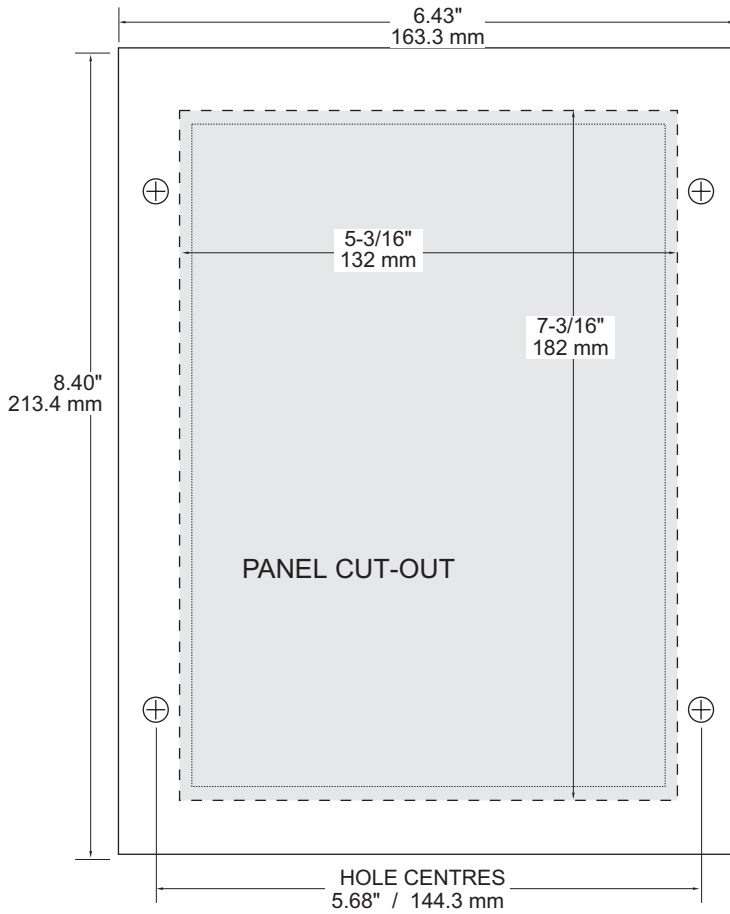

**INSTRUCTIONS**

Mark Panel using Flange as a Template.  
Cut Panel outside the line.

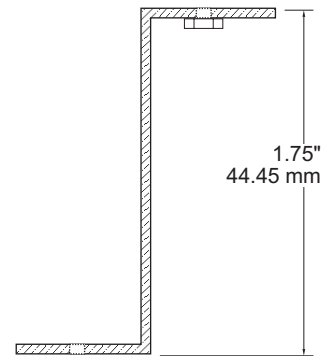

**Z-BRACKET**

QTY 2 INCLUDED WITH MOUNTING SCREWS

**FLANGE**

QTY 1 INCLUDED  
MATERIAL: 0.062 ALUMINUM  
FINISH: CLEAR IRIDITE

**INSTALLATION**

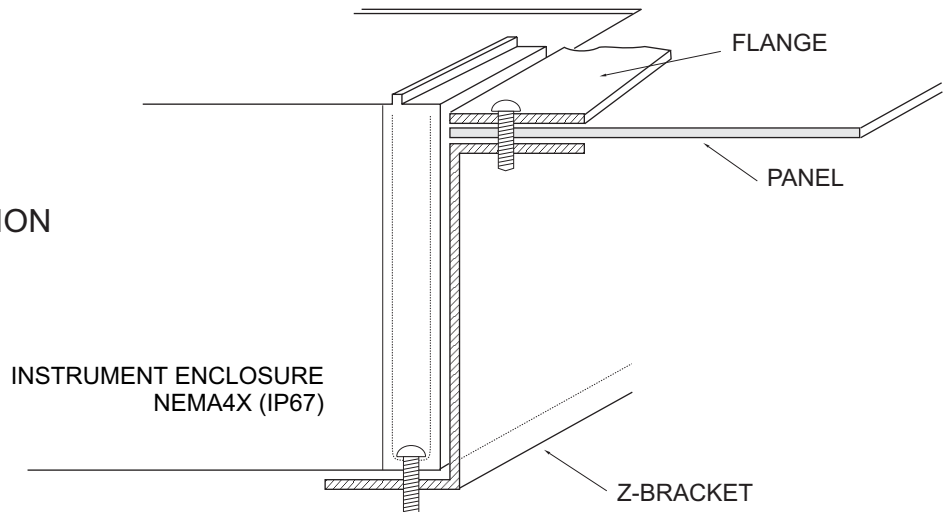

**ENCLOSURE SUNSCREEN - Option SCR**

Do not mount instrument electronics in direct sunlight. Overheating will reduce the life of electronic components and condensate may form during the heat/cool cycles and cause electrical shorts.

Note:

Exposure to direct sunlight can cause overheating and moisture condensation which will reduce the operating life of electronics.

Protect Instruments from direct sunlight with this iridite finished aluminum sun screen (Greyline Option SCR).

Seal conduit entries with caulking compound to further reduce moisture condensation.

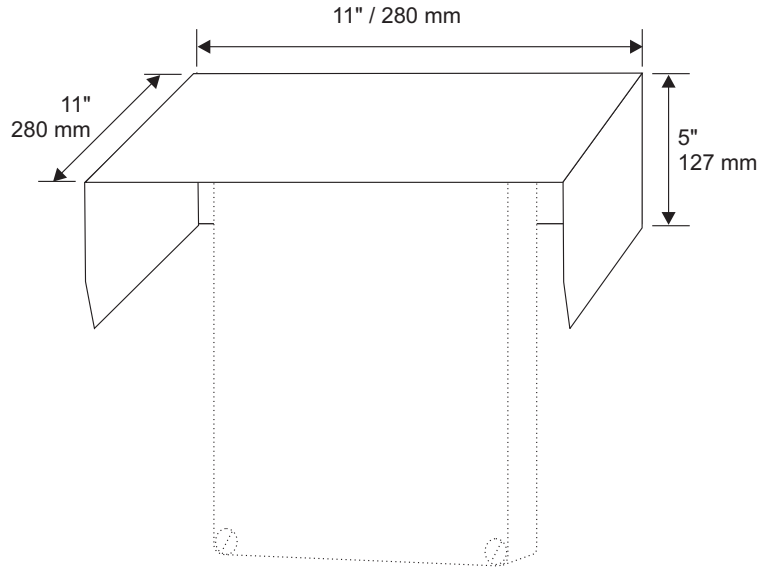

**SENSOR SUNSCREEN - OPTION PZS**

INSTALLATION

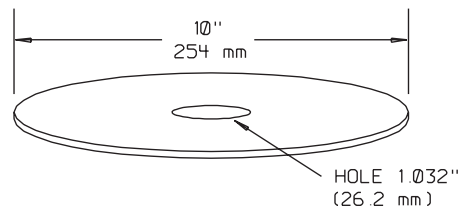
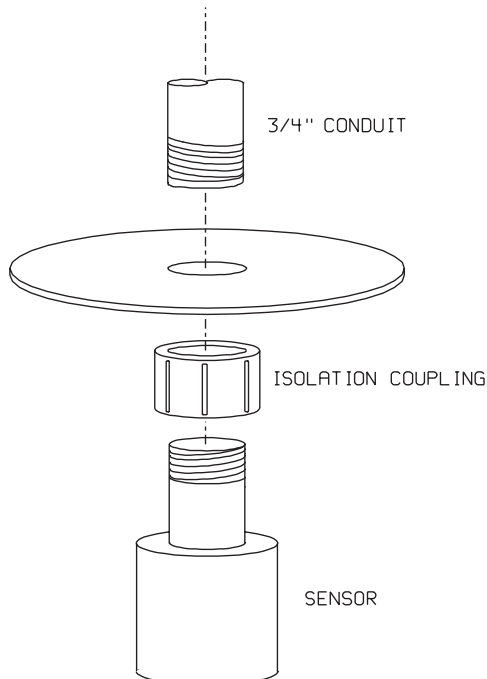

MATERIAL:  
1/16" ANODIZED ALUMINUM

NOTE:  
USE WHEN SENSOR IS INSTALLED IN DIRECT SUNLIGHT.

## APPENDIX B - APPLICATIONS BACKGROUND

Conditions in the tank where the ultrasonic sensor is installed can affect the performance, range and accuracy of the system. The following notes are for general reference. Contact Greyline Instruments or your local representative for specific information on your application.

**FOAM** - Solid or dense surfaces such as a smooth liquid surface will give the best echoes in an ultrasonic level measuring system. Foam acts as a sound insulator and may eliminate, or reduce the strength of an echo. Measurement range may be reduced in a system where foam is present. Ultrasonics are not recommended where thick dense foam is continually present. Intermittent or thin layers of light foam (1/8 in. or less) can generally be disregarded. Use a stilling well in open channel applications.

**LIQUIDS** - The LIT25 is ideal to monitor tank liquid level or inventory. Caustic, corrosive or very viscous liquids can be monitored without contacting the liquid.

**SOLIDS** - The LIT25 will measure most granular material and powders as well as liquids. Powders will not generally provide the same echo strength as liquids. Therefore maximum expected range should be reduced to approximately 20 feet (6 m) for powders. There are many exceptions to this rule and installation of a test system is recommended when in doubt.

**DUST** - Any obstructions to the sound will affect performance of the system. In silo's where heavy concentrations of dust are expected ultrasonics may not work. Where moderate dust is encountered care should be taken to mount the sensor in a position where dust accumulation will be minimized and where the sensor can be cleaned if necessary.

**SENSOR TEMPERATURE** - The standard sensor model PZ32T supplied with each Level Indicating Transmitter includes a built-in temperature sensor. The LIT25 automatically compensates for temperature fluctuations to retain high accuracy. Note the operating temperature ranges listed in the product specifications section. Do not exceed the sensor temperature ratings or damage may occur.

**ELECTRONICS TEMPERATURE** - Note operating temperature ranges listed in the product specifications. Temperatures higher than the maximum shown can reduce the operating life of the electronics. Moisture condensation from those temperatures below the range shown can also damage electronics components.

**NOISE** - Because the LIT25's sensor operates at high sound frequency, regular process noise or vibration will not affect the system. Ultrasonic Sensors installed in close proximity to one another in the same tank may "cross-talk" and should be relocated.

**VAPOUR** - May affect operation. Severe vapour stratification can cause false echoes. Variable vapour cannot be compensated.

**CHEMICAL COMPATIBILITY** - The LIT25 Sensor is constructed of very durable materials with broad compatibilities. Tank contents should be checked for their compatibility with PVC. An all-teflon sensor is available for corrosive applications.

CONVERSION GUIDE		
FROM	TO	MULTIPLY BY
US GALLONS	CUBIC FEET	0.1337
US GALLONS	IMPERIAL GALS	0.8327
US GALLONS	LITRES	3.785
US GALLONS	CUBIC METERS	0.003785
LITRES/SEC	GPM	15.85
LITRES	CUBIC METERS	0.001
BARRELS	US GALLONS	42
BARRELS	IMPERIAL GALS	34.9726
BARRELS	LITRES	158.9886
INCHES	MM	25.4
DEGREES F	DEGREES C	(°F-32) x 0.556
POUNDS	KILOGRAMS	0.453
PSI	BAR	0.0676
FOOT <sup>2</sup>	METER <sup>2</sup>	0.0929

VOLUME CALCULATION FOR ROUND TANKS:  $3.142 \times R^2 \times H$

R = TANK RADIUS (½ TANK DIAMETER)

H = TANK HEIGHT

**SPECIFICATIONS**

- Electronics Enclosure:** NEMA4X (IP 67), watertight and dust tight, fiberglass with clear, shatterproof Lexan cover
- Accuracy:**  $\pm 0.25\%$  of Range or 2 mm (0.08"), whichever is greater, Repeatability: 0.1%, Linearity: 0.1%
- Display:**  $\frac{3}{4}$ " / 19 mm high, 4 digit LCD
- Programming:** 2-button Menu selection. Calibration parameters are permanent when Stored (even through power interruptions)
- Power Input:** 100-130VAC  
50/60Hz, (6 W max.)  
Optional: 200-250VAC  
50/60Hz, (6 W max.)  
Optional: 24VDC, (4.32 W max.)  
Fuse: internal, rated 0.5A
- Output:** Isolated 4-20mA, 1000 ohm load maximum
- Signal Relay:** Qty 1, rated 120/240VAC or 24VDC, 1 ampere
- Temperature Compensation:** Automatic, temperature probe built in to level Sensor
- Electrical Surge Protection:** Sensor, 4-20mA, AC power input
- Operating Temperature:** -13 to 140°F (-25 to 60°C)  
(Electronics)

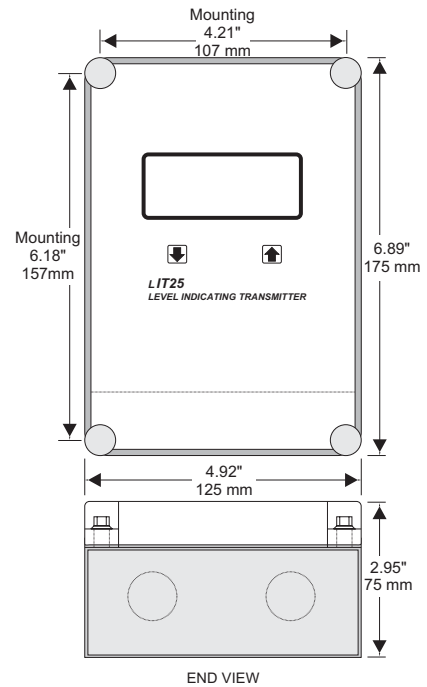

**Standard Sensor PZ32T**

- Maximum Range:** 32 ft. (10 m)
- Deadband (blinking):** Programmable, minimum 12" (305 mm)
- Beam Angle:** 8°
- Operating Frequency:** 42 KHz
- Exposed Materials:** PVC and Teflon
- Operating Temperature:** - 40° to 150°F (-40° to 65°C)
- Operating Pressure:** 20 psi (1.35 Bar) maximum
- Mounting:**  $\frac{3}{4}$ " NPT (PVC isolation coupling supplied)
- Sensor Cable:** RG62AU coaxial, 25 ft. (7.6 m) standard length
- Maximum Cable Length:** 500 ft. (152 m) RG62AU coaxial
- Hazardous Rating:** with optional Intrinsic Safety Barrier: CSA, Class I,II,III, Div. I,II, Groups C,D,E,F,G

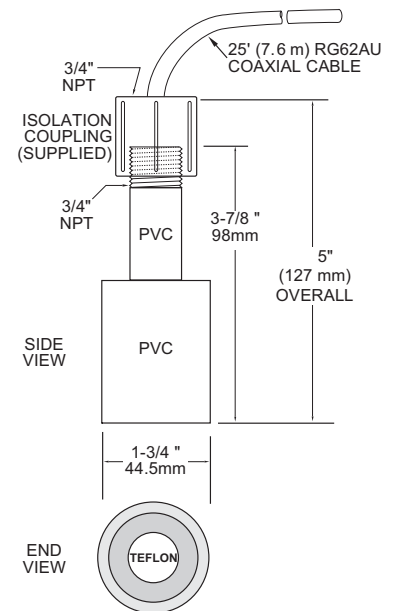



**Optional Sensor PZ32TE**

- Maximum Range:** 32 ft. (10m)
- Deadband (blanking):** Programmable, minimum 12" (305 mm)
- Beam Angle:** 8°
- Operating Frequency:** 42 KHz
- Exposed Materials:** Teflon
- Operating Temperature:** -40° to 170°F (-40° to 76°C)
- Operating Pressure:** 20 psi (1.35 Bar) maximum
- Mounting:** 3/4" NPT (Teflon isolation coupling supplied)
- Sensor Cable:** RG62AU coaxial, 25 ft. (7.6 m) standard length
- Maximum Cable Length:** 500 ft. (152 m) RG62AU coaxial with optional Intrinsic Safety Barrier:
- Hazardous Rating:** CSA, Class I,II,III, Div. I,II, Groups C,D,E,F,G,

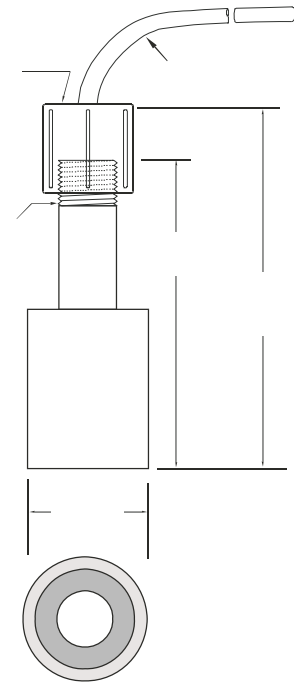

**Optional PZ52T**

- Maximum Range:** 50 ft. (15.6 m)
- Minimum Range (Deadband):** 16 in. (406 mm)
- Operating Frequency:** 40 kHz
- Beam Angle:** 8°
- Temperature Compensation:** Automatic, continuous
- Operating Temperature:** -40 to 150°F (-40 to 65°C)
- Max. Operating Pressure:** 20 psi (1.35 Bar)
- Sensor Face:** Teflon
- Sensor Housing:** PVC
- Sensor Mounting:** 3/4" NPT (Isolation Coupling supplied)
- Sensor Cable:** 50 ft. (15 m) continuous
- Maximum Cable Length:** 500 ft. (152 m)
- Hazardous Rating:** CSA rated Intrinsically Safe Class I, Groups C,D, Class II, Groups E,F,G with Optional Intrinsic Safety Barrier.  
Note: Max Range reduced to 32 ft (10 m) with ISB option

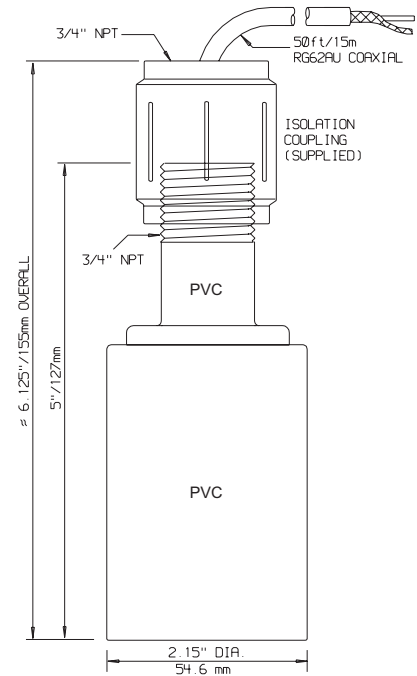

**Optional PZ12**

- Maximum Range:** 12 ft (3.66 m)
- Minimum Range (Deadband):** 8" (203.2 mm)
- Operating Frequency:** 92 KHz
- Beam Angle:** 8°
- Operating Temperature:** -40° to 150° (-40° to 65°C)
- Temperature Compensation:** Automatic, continuous
- Max. Operating Pressure:** 20 psi (1.35 bar)
- Sensor Face:** PVC
- Sensor Body:** PVC
- Mounting:** 3/4" NPT
- Cable Length:** 25 ft. (7.6 m) continuous RG62AU coaxial. Optional 50 ft. (15 m) continuous
- Max. Cable Length:** 500 ft. (152 m) RG62AU coaxial (splice)
- Hazardous Rating:** CSA rated Intrinsically Safe Class I, Groups C,D, Class II, Groups E,F,G with Optional Intrinsic Safety Barrier.

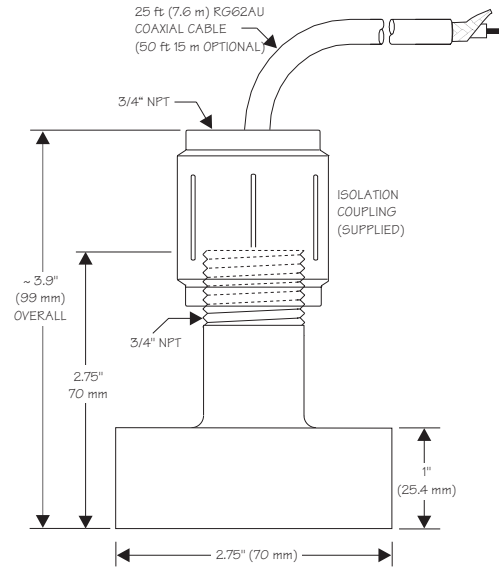

**Optional PZ12T\_F**

- Maximum Range:** 12 ft (3.66 m)
- Minimum Range (Deadband):** 8"(203.2 mm)
- Operating Frequency:** 92 KHz
- Beam Angle:** 8°
- Operating Temperature:** -40° to 150° (-40° to 65°C)
- Temperature Compensation:** Automatic, continuous
- Max. Operating Pressure:** 20 psi (1.35 bar)
- Sensor Face:** Teflon
- Sensor Body:** PVC
- Mounting:** 3/4" NPT
- Cable Length:** 25 ft. (7.6 m) continuous RG62AU coaxial. Optional 50 ft. (15 m) continuous
- Max. Cable Length:** 500 ft. (152 m) RG62AU coaxial (splice)
- Hazardous Rating:** CSA rated Intrinsically Safe Class I, Groups C,D, Class II, Groups E,F,G with optional Intrinsic Safety Barrier.

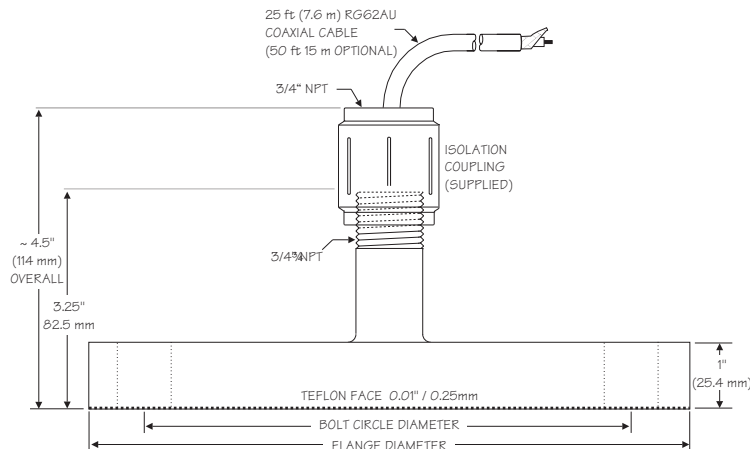

**Optional PZ34**

- Maximum Range:** 32 ft. (10 m)
  - Minimum Range (Deadband):** 16" (406.4 mm)
  - Operating Frequency:** 46 KHz
  - Beam Angle:** 8°
  - Temperature Compensation:** Automatic, continuous
  - Operating Temperature:** -40° to 150°F (-40° to 65°C)
  - Maximum Operating Pressure:** 20 psi (1.35 Bar)
  - Exposed Materials:** PVC
  - Sensor Mounting:** 3/4" NPT
  - Maximum Cable Length:** 500 ft (152 m)
  - Optional Hazardous Rating:** CSA rated Intrinsically Safe Class I, Groups C,D, Class II, Groups E,F,G with optional Intrinsic Safety Barrier.
- Note:** Max Range reduced to 25 ft (7.8 m) with ISB option.

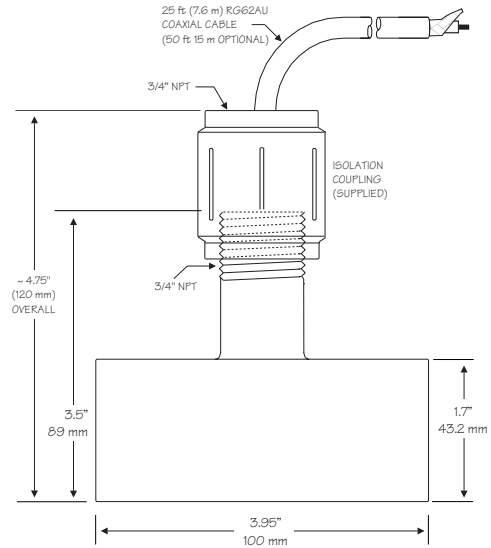

**Optional PZ34T\_F**

- Maximum Range:** 32 ft. (10 m)
- Minimum Range (Deadband):** 16" (406.4 mm)
- Operating Frequency:** 46 KHz
- Beam Angle:** 8°
- Temperature Compensation:** Automatic, continuous
- Operating Temperature:** -40° to 150°F (-40° to 65°C)
- Maximum Operating Pressure:** 20 psi (1.35 Bar)
- Sensor Face:** Teflon
- Sensor Body:** PVC (not exposed to tank contents)
- Cable Length:** 25 ft. (7.6 m) continuous RG62AU coaxial Optional 50 ft. (15 m) continuous
- Maximum Cable Length:** 500 ft (152 m) RG62AU coaxial (splice)
- Hazardous Rating:** CSA rated Intrinsically Safe Class I, Groups C,D, Class II, Groups E,F,G with optional Intrinsic Safety Barrier.

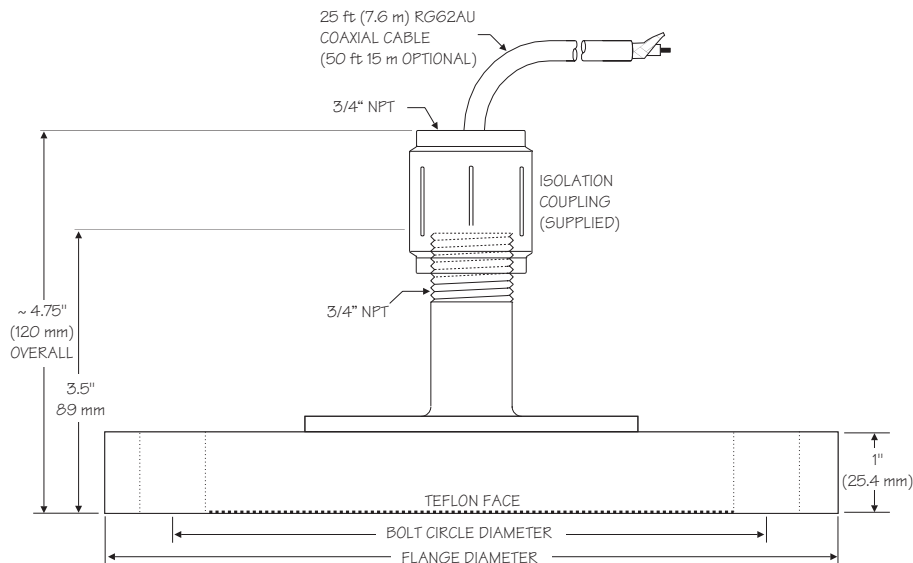

### LIT25 Calibration Record

SERIAL # \_\_\_\_\_

DATE: \_\_\_\_\_

Circle Selected Units and  
Enter Values in the Blank  
Spaces

