

## Installation and Operating Instructions

### Compact Heat Meter

### Compact Heat/Cooling Meter

### Compact Cooling Meter

## **SensoStar** Ultrasonic, Single-Jet and Multi-Jet Heat Meters

DE-16-MI004-PTB025 (MID heat)

DE-16-M-PTB-0097 (national German cooling)

### 1 Application and Function

This **SensoStar** is designed for the measurement of the consumed energy in a closed heating, cooling or heating / cooling system.

### 2 Contents of the Package

- Heat meter or heat/cooling meter, consisting of a calculator, a flow sensor and two temperature sensors, all permanently connected to each other
- Installation kit (depending on type)
- Installation and Operating Instructions
- Operating Instructions „Communication Interfaces“
- Declaration of Conformity



### 3 General Information

- Valid standards for the application of heat meters: EN 1434, parts 1 – 6; the Measuring Instruments Directive 2014/32/EU, Annexes I and MI-004; and the relevant national verification regulations.
- For the selection, installation, commissioning, monitoring and maintenance of the instrument observe the standard EN 1434 part 6, as well as the verification regulations PTB TR K8 + K9 for Germany (and any relevant national verification regulations in other countries).
- National regulations for the consumption measurement of cooling must be observed.
- The technical regulations for electrical installations must be observed.
- This product fulfils the requirements of the European Council Directive on Electromagnetic Compatibility (EMC Directive) 2014/30/EU.
- The identification plate of the instrument and the seals must not be removed or damaged – otherwise the guarantee and the approved application of the instrument are no longer valid!
- To achieve measurement stability of the meter it is necessary that the water quality meet the requirements of the AGFW-recommendation FW-510 and the document VDI (Association of German Engineers) VDI 2035.
- The heat meter left the factory in conformance with all applicable safety regulations. All maintenance and repair work is to be carried out only by qualified and authorized technical personnel.
- The instrument must be stored and transported at temperatures above-freezing.
- **Instruments with activated radio function are not allowed on air freight.**
- The correct installation point in the system must be chosen: forward or outlet flow (see item 3.1 'Pictograms installation point').
- The temperature sensor cables and the cable between the calculator and flow sensor must not be kinked, rolled up, lengthened or shortened.
- To clean the heat meter (only if necessary) use a slightly moist cloth.
- To protect against damage and dirt the heat meter should only be removed from the packaging directly before installation.
- If more than one heat meter is installed in one unit, care must be taken to ensure that all the meters have the same installation conditions.
- All specifications and instructions listed on the data sheet and in the Application Notes must be adhered to.
- Further information can be obtained at [www.engelmann.de](http://www.engelmann.de).
- Instruments which have been replaced or exchanged must be disposed of according to relevant environmental regulations.
- The display is deactivated and can be activated for two minutes by pushing the button.



- Unit of energy and installation point (outlet flow / inlet flow) can be set on location, only once, before start of operation by pushing the button or alternatively using the „Device Monitor“ software.
- Type and concentration of glycol in the medium of those mechanical meter types designed to be used with glycol can be set on location, only once, before start of operation using the „Device Monitor“ software (see item 7.1 for details).

### 3.1 Pictograms installation point

On the right in the meter display in all information loops you will find one of the following two pictograms. The pictogram indicates in which pipe the meter is to be mounted.

	Installation in outlet flow
	Installation in inlet flow

### 3.2 Pictograms type of meter (on type identification label)

	Heat meter
	Cooling meter

## 4 Mounting the Flow Sensor

### 4.1 Mounting of **SensoStar E**, **SensoStar Q** and **SensoStar U**

- Flush the pipes professionally, taking care not to damage any system components. Then close all the shut-off valves.
- Open the nearest draining valve for pressure release.
- Drain the closed-off pipe section.
- Loosen the coupling rings and remove the old heat meter.
- Remove all old gaskets and clean the sealing surfaces. Insert new gaskets.
- Position the flow sensor correctly, taking into account the direction of flow (arrow on the side of the flow sensor)!
- Tighten the coupling rings.
- Rotate the calculator to the best position for read-out, or detach it and mount it nearby.

Note concerning **SensoStar U**: For the mounting in a heating system with a small quantity of air in the medium we recommend to overturn the meter through 90°.

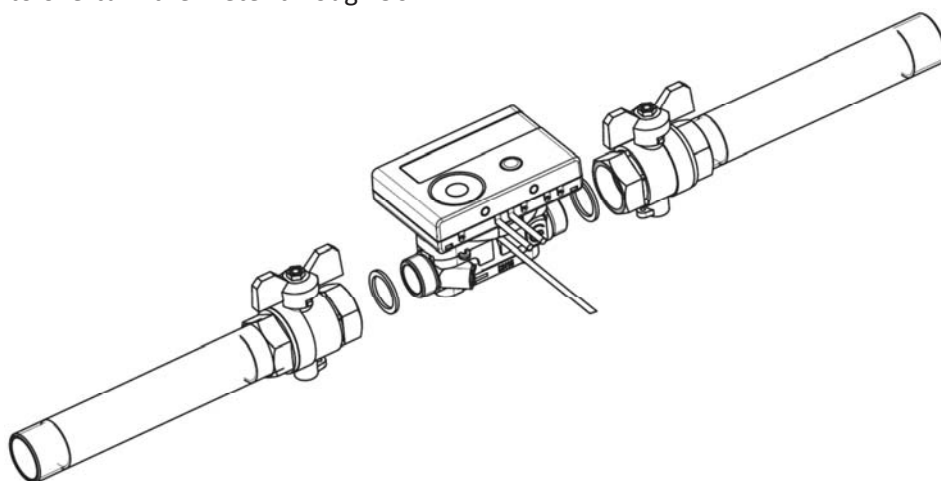

### 4.2 Installation of **SensoStar I** in a fix installed single pipe connection piece

The multi-jet flow sensor type MSH-IST has a 2" connection as described in EN 14154 (IST; interface for Ista heat meters) and must be installed without an adapter.

### Mounting the flow sensor type MSH-IST in a single pipe connection piece

- Flush the pipes professionally, taking care not to damage any system components. Then close all the shut-off valves. Open the nearest draining valve for pressure release.
- Drain the closed-off pipe section.
- Take into account the direction of flow (check the connection piece)!
- Remove the overflow flange or the old heat meter from the connection piece using a wrench.
- Remove all old gaskets. Check sealing surfaces and threads for imperfections or dirt. If necessary, debur or clean with a suitable cleaning liquid.
- Place the new profile gasket into the connection piece with the flat surface facing up.
- Lubricate the external thread of the flow sensor with a thin layer of food safe silicon grease.
- Check that the O-ring on the outlet of the flow sensor is in the correct position.
- Screw in the heat meter tightly by hand and then tighten additionally with a suitable wrench to the mechanical end stop (metal-to-metal).
- Rotate the calculator to the best position for read-out, or detach it and mount it nearby.

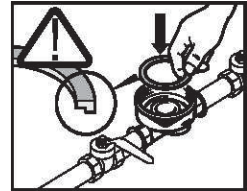

### 4.3 Installation of *SensoStar T* in a fix installed single pipe connection piece

The multi-jet flow sensor type MSH-TE1 has an M62x2 thread as described in EN 14154 (TE1; interface for Techem heat meters) and must be installed without an adapter.

### Mounting the flow sensor type MSH-TE1 in a single pipe connection piece

- Flush the pipes professionally, taking care not to damage any system components. Then close all the shut-off valves. Open the nearest draining valve for pressure release.
- Drain the closed-off pipe section.
- Take into account the direction of flow (check the connection piece)!
- Remove the overflow flange or the old heat meter from the connection piece using a wrench.
- Remove all old gaskets. Check sealing surfaces and threads for imperfections or dirt. If necessary, debur or clean with a suitable cleaning liquid.
- Lubricate the external thread of the flow sensor with a thin layer of food safe silicon grease.
- Check that the O-ring on the outlet of the flow sensor is in the correct position.
- Screw in the heat meter tightly by hand and then tighten additionally with a suitable wrench to the mechanical end stop (metal-to-metal).
- Rotate the calculator to the best position for read-out, or detach it and mount it nearby.

### 4.4 Installation of *SensoStar M* in a fix installed single pipe connection piece

The multi-jet flow sensor type MSH-M60 has an M60x1,5 thread as described in EN 14154 (M60; interface for Minol heat meters) and must be installed without an adapter.

### Mounting the flow sensor type MSH-M60 in a single pipe connection piece

- Flush the pipes professionally, taking care not to damage any system components. Then close all the shut-off valves. Open the nearest draining valve for pressure release.
- Drain the closed-off pipe section.
- Take into account the direction of flow (check the connection piece)!
- Remove the overflow flange or the old heat meter from the connection piece using a wrench.
- Remove all old gaskets. Check sealing surfaces and threads for imperfections or dirt. If necessary, debur or clean with a suitable cleaning liquid.
- Place the new profile gasket into the connection piece with the flat surface facing up.
- Lubricate the external thread of the flow sensor with a thin layer of food safe silicon grease.
- Check that the O-ring on the outlet of the flow sensor is in the correct position.
- Screw in the heat meter tightly by hand and then tighten additionally with a suitable wrench to the mechanical end stop (metal-to-metal).
- Rotate the calculator to the best position for read-out, or detach it and mount it nearby.

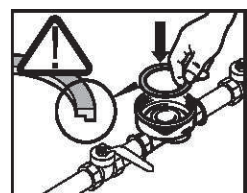

#### 4.5 Installation of **SensoStar A** in a fix installed single pipe connection piece

The multi-jet flow sensor type MSH-A1 has an M77x1,5 thread as described in EN 14154 (A1; interface for Allmess heat meters) and must be installed without a conversion adapter.

##### Mounting the flow sensor type MSH-A1 in a single pipe connection piece

- Flush the pipes professionally, taking care not to damage any system components. Then close all the shut-off valves. Open the nearest draining valve for pressure release.
- Drain the closed-off pipe section.
- Take into account the direction of flow (check the connection piece)!
- Remove the overflow flange or the old heat meter from the connection piece using a wrench.
- If a plastic adapter was mounted together with the old meter, it must also be removed.
- Check sealing surfaces and threads for imperfections or dirt. If necessary, debur or clean with a suitable cleaning liquid.
- Lubricate the external thread (M77x1,5) of the flow sensor and the O-ring (66,35x2,62) with a thin layer of food safe silicon grease.
- Screw in the heat meter tightly by hand and then tighten additionally with a suitable wrench to the mechanical end stop (metal-to-metal).
- Use the black sealing piece to seal the EAT by inserting the seal in one of the two designated spots.
- Rotate the calculator to the best position for read-out, or detach it and mount it nearby.

##### Attention!

When installing, ensure correct positioning regarding the flow by paying attention to the directional arrows on the EAT connection piece and on the bottom of the plastic adapter. Also, make sure that the blind hole in the plastic adapter is properly lined up with the metal pin in the inside bottom of the EAT on the flow outlet. (In rare cases, this pin may not be present: In this case, it is not necessary for installation.)

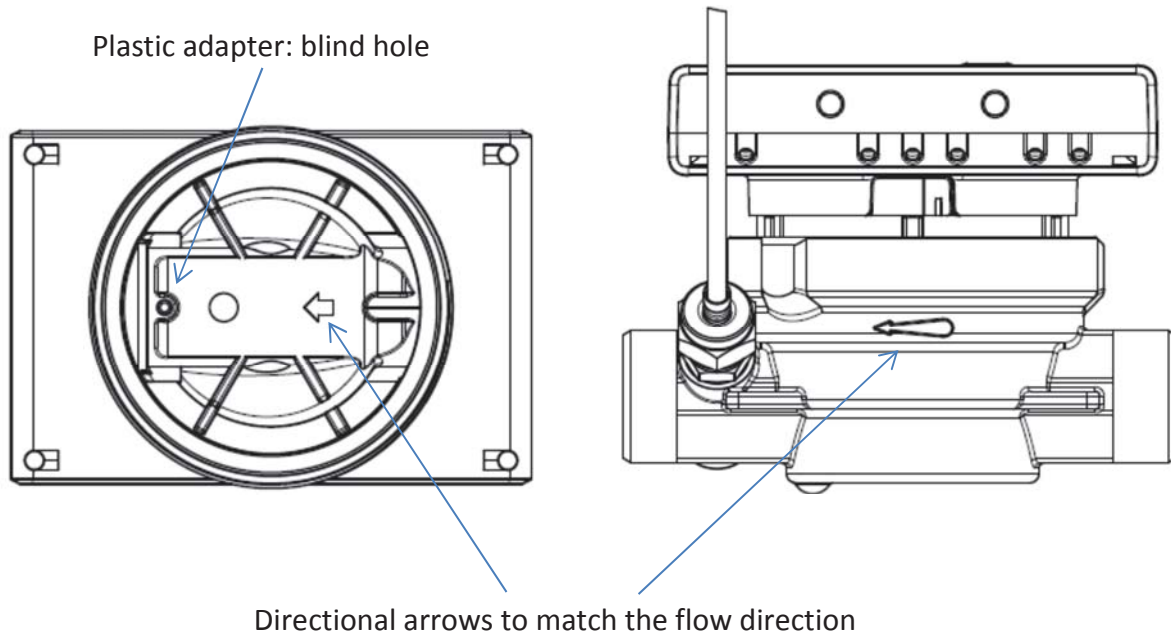

#### 5 Detachable Calculator:

We also provide meters with detachable calculators, in order to simplify mounting in narrow installation spaces. To release the calculator pull it carefully up off the flow sensor.

For mounting the calculator on the wall, a wall support is latched onto the adapter of the flow sensor (between calculator and flow sensor; you will notice it after removing the calculator). To release the wall mounting support rotate the calculator anticlockwise. Then attach the wall support at the desired place **with the flat surface towards the wall.**

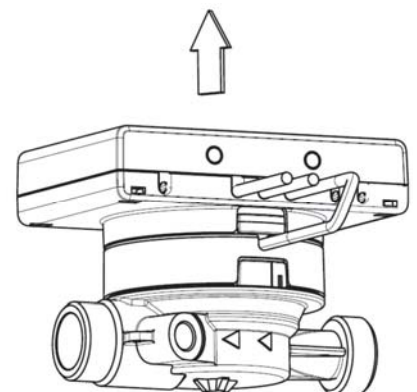

We always recommend detaching the calculator from the flow sensor.

However, it is important to note that the calculator must be detached for the following versions:

- Cooling and heat/cooling meters
- high temperature heat meter versions **SensoStar U** (temperature range up to 130 °C)
- high temperature heat/cooling meter versions **SensoStar U** (temperature range up to 120 °C).

## 6 Mounting the Temperature Sensors

During installation of two exterior temperature sensors make sure that the temperature sensor marked with the symbol illustrated is mounted into the same pipe line as the flow sensor.

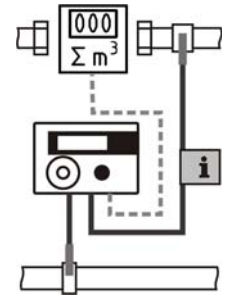

### 6.1 Direct mounting (ball valve and T-piece)

- Remove the blind plug / old temperature sensor and gasket / old O-ring. Clean connection surfaces.
- **Slide the O-ring off the temperature sensor and insert it to the bottom of the threaded opening of the ball valve or the T-piece.**
- Hold the temperature sensor at the screw only and insert it into the ball valve or the T-piece and screw tightly.
- **In doing so the plastic clip is locked in the first crimp (viewed from the top of the protective sheath) and must not be moved.**



### 6.2 Direct mounting of the 6 mm temperature sensors of the **SensoStar A**

Important notes:

- Close the shut-off valves and make sure that no hot water can escape upon removal of the blind plug or the old temperature sensor!
- Prepare both temperature sensors: Push the O-ring into the first crimp (seen from the top of the protective sheath).
- Insert the temperature sensors into the measuring point of the EAT, and ball valve or T-piece, and tighten using the coupling nuts.
- Reopen all ball valves and check installation points for leakage.
- Protect the installation points (meter and temperature sensors) against manipulation by securing with the seals and sealing wires.

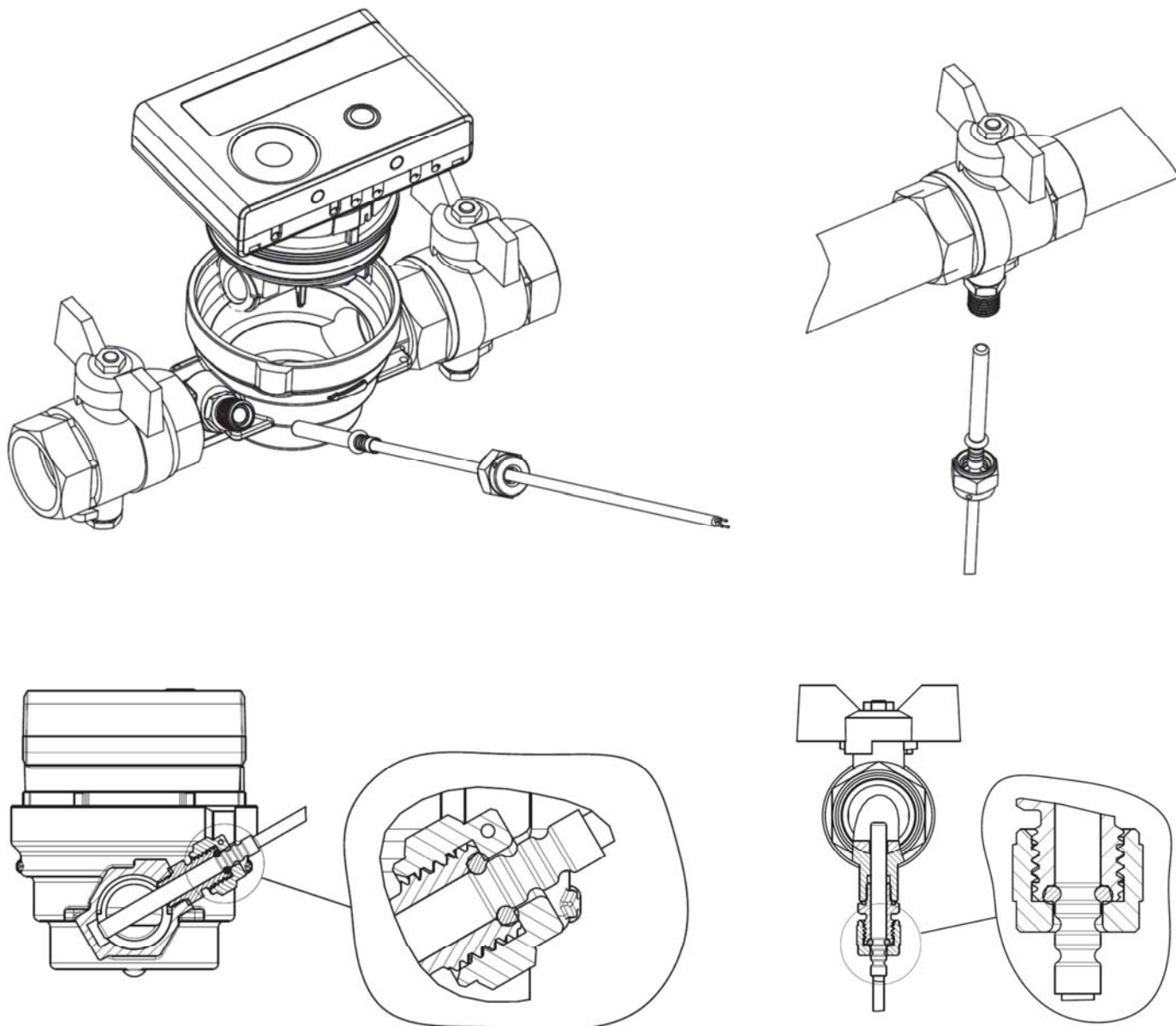

## 7 Start of Operation

- Slowly open the shut-off valves.
- Check that there are no leaks.

### Check the following points:

- Are all shut-off valves open?
- Is the meter of the right size?
- Is the heating (heating/cooling) system clear (dirt filters not clogged)?
- Is the temperature sensor installed in the flow sensor correctly sealed to the flow sensor?
- Does the directional arrow on the flow sensor match the actual direction of flow?
- Is a flow volume displayed?
- Is a plausible temperature difference displayed?

When the meter is functioning properly, attach the seals to the exterior temperature sensors and the flow sensor (required to protect against manipulation).

## 8 Display













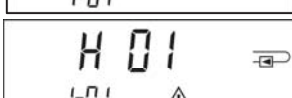



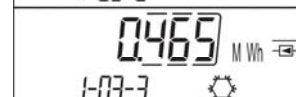





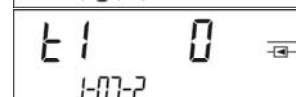

The calculator has a liquid crystal display with 8 digits and special characters. The values that can be shown are divided into five display loops. All data is retrieved using the push-button next to the display. At the start you are automatically in the main loop (1st level).

By pressing the push-button longer than 4 seconds you change to the next display loop. Keep the push-button pressed until you reach the desired information loop.

By pressing the push-button briefly each time you can scan all the information within a loop.

After 2 minutes of non-use of the push-button, the display will automatically be deactivated.

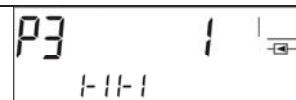





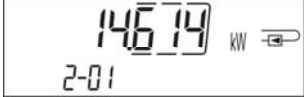
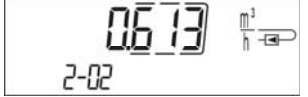

### Level 1 / Main Loop:

    <p>1) Total heat energy since start of operation (standard display); alternating display: cooling energy (for heat/cooling meter); when negative flow; information message (if an error was detected)</p>	 <p>2) Segment test on / off (all segments triggered simultaneously)</p>	      <p>3) Last reading date alternating with heat energy (cooling energy), volume, value tariff register 1, value tariff register 2 at last reading date<sup>1) 2)</sup></p>	 <p>4) Total flow volume in m<sup>3</sup></p>
  <p>5) Current date alternating with time</p>	  <p>6) Information message (alternating binary and hexadecimal display)</p>	  <p>7) Tariff register 1: value alternating with tariff register no. and criteria<sup>2)</sup></p>	  <p>8) Tariff register 2: value alternating with tariff register no. and criteria<sup>2)</sup></p>
  <p>9) Pulse counter 1: pulse value alternating with reading<sup>2)</sup></p>	  <p>10) Pulse counter 2: pulse value alternating with reading<sup>2)</sup></p>	  <p>11) Pulse counter 3: pulse value alternating with reading<sup>2)</sup></p>	



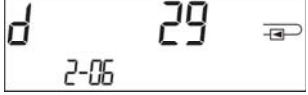

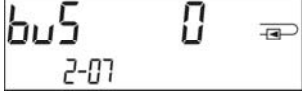

<sup>1)</sup> Up to the end of the month the consumption and reading date for that month will be shown as 0.

2) Two tariff registers are an option available as part of the original order. - Three pulse inputs are also an option. They can be set using the software „Device Monitor“. A dedicated meter password is necessary. The password is available from the manufacturer.











**Level 2 / Technician's Loop:**

 <p>2-01</p> <p>1) Current power in kW</p>	 <p>2-02</p> <p>2) Current flow in m<sup>3</sup>/h. (When negative flow, value is displayed negative.)</p>	 <p>2-03</p> <p>3) Inlet flow temperature in °C</p>	 <p>2-04</p> <p>4) Outlet flow temperature in °C</p>
 <p>2-05</p> <p>5) Temperature difference in K. (Cooling energy: Value is displayed negative.)</p>	 <p>2-06</p> <p>6) Before start of operation: days since manufacture</p>  <p>2-06-1</p>  <p>2-06-2</p> <p>After start of operation: days since manufacture alternating with days of operation after reaching an energy value &gt; 10 kWh</p>	 <p>2-07</p> <p>7) M-bus address</p>	 <p>2-08</p> <p>8) Serial number</p>
 <p>2-09</p> <p>9) Firmware version</p>			

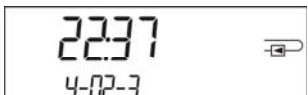
**Level 3 / Statistics Loop:**

 <p>3-01-1</p>  <p>3-01-2</p>  <p>3-01-3</p>	 <p>3-01-4</p>  <p>3-01-5</p>  <p>3-01-6</p>	<p>1) – 30) Semimonthly values: date alternating with heat energy, cooling energy, volume, value tariff register 1, value tariff register 2</p>	
--	---	---	--

**Level 4 / Maximum Values Loop:**

 <p>4-01-1</p>  <p>4-01-2</p>  <p>4-01-3</p> <p>1) Maximum power alternating with date and time</p>	 <p>4-02-1</p>  <p>4-02-2</p>  <p>4-02-3</p> <p>2) Maximum flow alternating with date and time</p>	 <p>4-03-1</p>  <p>4-03-2</p>  <p>4-03-3</p> <p>3) Maximum inlet flow temperature alternating with date and time</p>	 <p>4-04-1</p>  <p>4-04-2</p>  <p>4-04-3</p> <p>4) Maximum outlet flow temperature alternating with date and time</p>
---	---	--	--



<p>5) Maximum temperature difference alternating with date and time</p>			

**Level 5 / Parametrizing Loop:**

<p>1) Parametrizing „unit of energy“</p>	<p>2) Parametrizing „installation point“</p>		

**8.1 Parametrizing loop**

The following characteristics of the meters can be set on location, **only once**, by pushing the button or alternatively using the „Device Monitor“ software:

- unit of energy (kWh; MWh; GJ; MMBTU, Gcal)
- installation point (inlet flow; outlet flow).

The following characteristic of those mechanical meter types designed to be used with glycol can be set on location, **only once**, using the „Device Monitor“ software:

- type and concentration of glycol in the medium (propylene glycol; ethylene glycol; 20 %; 30 %; 40 %; 50 %).

**The parametrizing options are only available when the amount of energy is still <= 10 kWh.**

Make sure that these characteristics are set as needed before starting up the system. In order to start the editing mode for parametrizing you must select the respective item in the parametrizing loop and then push the button once again for 2-3 seconds. As an aid, after 2 seconds the „editing pen“ will be displayed bottom left in the LCD (see below picture). As soon as it appears you have to let go of the button. Then the current display will start blinking.



By pressing the push-button briefly you can switch to the next option. By pressing the push-button longer the currently displayed option will be set. If no option is chosen there will be no change and as soon as the LCD goes out the edit mode will end automatically.

**8.2 Detection of flow**

As long as the meter detects some flow the following pictogram will be displayed bottom right in the LCD.

	<p>flow detected</p>
--	----------------------

## 9 Application Conditions

<b>SensoStar</b>		
Maximum flow $q_s/q_p$		2:1
Mechanical class		M1
Electromagnetic class		E2
Environmental class		C
Protection class flow sensor		IP65
Nominal pressure PN	bar	16
Mounting position		any, if there is no indication on type label
<b>Flow sensor of <i>SensoStar E</i> and <i>SensoStar</i> multi-jet heat meters</b>		
Temperature range heat	°C	15 - 90
Temperature range cooling	°C	5 – 50 ( $q_p$ 1,5 and $q_p$ 2,5)
<b>Flow sensor of <i>SensoStar U</i></b>		
Temperature range heat	°C	15 - 90 standard 15 - 130 high temperature (150; for maximal 2000 h)
Temperature range cooling	°C	5 – 50 (from $q_p$ 1,5 to $q_p$ 6)
Temperature range heat/cooling	°C	15 - 90 heat standard 15 - 120 high temperature 5 - 50 cooling
<b>Calculator</b>		
Ambient temperature	°C	5 - 55 at 95 % relative humidity, see „Influencing_factors_battery_lifetime“ at <a href="http://www.engelmann.de">www.engelmann.de</a>
Protection class		IP65

## 10 Interfaces and Options

### 10.1 Optical (infrared) interface

For communication with the optical interface an optocoupler and the “Device Monitor” software are necessary. The optocoupler and “Device Monitor” are available as accessory equipment.

The optical infrared interface must be activated by sending a header (according to EN 13757-3). Baud rate: 2400 baud.

Then you can communicate with the meter for 4 seconds. After every valid communication the meter is open for another 4 seconds. Afterwards the display is deactivated.

The number of read-outs per day via the optical interface is limited. During daily read-out at least 4 communications are possible. If read-outs are carried out more rarely, the possible number of communications will increase.

### 10.2 Retrofitting with an additional communication interface (optional)

We also offer a retrofittable meter to which communication interfaces can be added later. You will find the description of our optional interfaces in the operating instructions „Communication Interfaces“.

To retrofit such a meter with an additional communication interface the device’s calculator has to be opened. Use a screwdriver with a wide tip (4 - 5 mm) and carefully press in the two round predetermined breaking points above the six cable feedthroughs. (You can see the two predetermined breaking points also in the illustration on page 4 bottom right.)

Then insert the screwdriver into one of the two openings at an angle of approx. 45° and carefully lift the handle up to approx. 90°. The upper housing piece of the calculator is then no longer latched on this side. Repeat this with the other opening. Now the upper housing piece can be taken off.

Plug the interface module on the right side of the PC board. The cables are to be fed through the rightmost cable feedthroughs (as viewed from the front) into the calculator after removing the blind grommets.

Close the calculator and protect against unauthorized opening using the enclosed seals.

### 10.3 Exchanging the Battery

The meter’s battery is easy to exchange by authorized technical personnel (Engelmann replacements only).

To exchange it first open the meter’s calculator as described above in 10.2. Connect the new battery, close the calculator and protect it against unauthorized opening using the enclosed seals.

Replaced batteries must be disposed of according to relevant environmental regulations.

### 10.4 Mounting a power pack

If an external power supply is needed, only the power pack designed for **SensoStar** may be used. To connect the power pack, first open the meter's calculator as described above in 10.2. Then remove the battery from the calculator and plug it into the battery connector in the power pack. (The battery is a backup in case of a power outage.)

Plug the service plug enclosed with the power pack onto the contact fingers on the left hand side of the PC board (see arrow below). Then feed the cable of the power pack through the meter's leftmost cable feedthrough (viewed from the front) after removing the blind grommet. The cable has two connectors: One of them is to be plugged into the female connector on the PC board, the other one is to be connected to the service plug.

**Only authorized technical personnel may connect the power pack to the 230 V mains supply and check it.**

When the meter detects external power supply the pictogram of a mains plug appears in the display lower left. Close the calculator and protect against unauthorized opening using the enclosed seals.

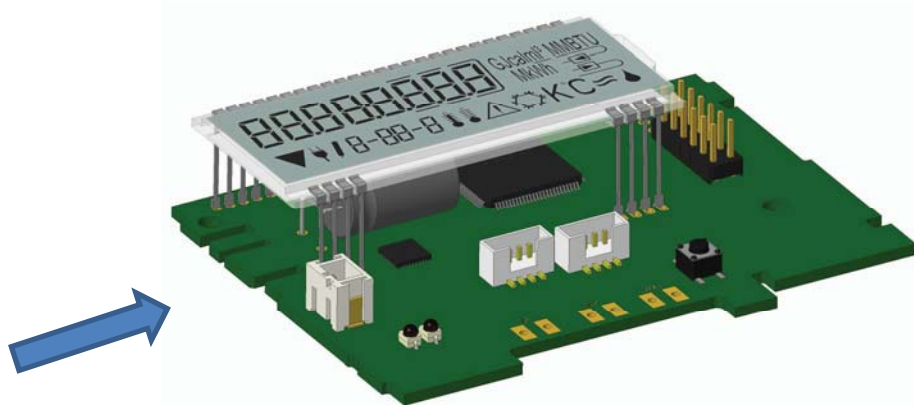

### 11 Information Messages

When the instrument has detected an information message, the message symbol is displayed:

The specific message can be found at menu item 6 'Information message' in level 1 / main loop (see section 7, Display). The message code is displayed alternately in binary and hexadecimal form.

The instrument recognizes eight message causes, which can also occur in combination with each other.

Binary display	Description	Hexadecimal display
1 at first place	Low battery	H 80
1 at second place	Instrument has been reset	H 40
1 at third place	Electronics defective	H 20
1 at fourth place	Error in flow measurement system	H 10
1 at fifth place	Temperature sensor 2 short circuit	H 08
1 at sixth place	Temperature sensor 2 cable break	H 04
1 at seventh place	Temperature sensor 1 short circuit	H 02
1 at eighth place	Temperature sensor 1 cable break	H 01

„Temperature sensor 1“ is the right temperature sensor (viewed from the front).

#### Example: Temperature sensor 1 cable break

Message	Low battery	Reset	Electronics defective	Error in flow measurement system	Temperature sensor 2 short circuit	Temperature sensor 2 cable break	Temperature sensor 1 short circuit	Temperature sensor 1 cable break	Alternating hexadecimal message displayed (LCD)
Bit	7	6	5	4	3	2	1	0	
Display location	1	2	3	4	5	6	7	8	

Alternating binary message displayed (LCD))		
---	---	---

When a message  appears in the standard display (total heat energy), with the exception of the messages

- Low battery (H 80)
- Reset (H 40)
- Error in flow measurement system (H 10; in the case of air in the ultrasonic measuring tube),

the instrument must be exchanged and sent to the supplier for examination.

### 11.1 Message description

Message	Effect	Possible cause
Low battery	No influence on the calculation	Adverse environmental conditions; long operating time
Reset	No influence on the calculation	EMC, electromagnetic interference
Electronics defective	No energy calculations are carried out. The register for energy is not being updated (no new data is being stored).	Defective component, defect on the calculator PC board
Error in flow measurement system	No calculations are carried out. The registers for volume and energy are not being updated (no new data is being stored).	Connecting cable between the calculator housing and flow sensor damaged <u>Ultrasonic flow sensor:</u> Air in the system; contaminated flow sensor <u>Mechanical flow sensor:</u> Scanning is not functioning properly
Temperature sensor 2 short circuit	No energy calculations. The register for energy is not being updated (no new data is being stored).	Sensor cable damaged
Temperature sensor 2 cable break	No energy calculations. The register for energy is not being updated (no new data is being stored).	Sensor cable damaged
Temperature sensor 1 short circuit	No energy calculations. The register for energy is not being updated (no new data is being stored).	Sensor cable damaged
Temperature sensor 1 cable break	No energy calculations. The register for energy is not being updated (no new data is being stored).	Sensor cable damaged

## 12 Manufacturer

Engelmann Sensor GmbH  
Rudolf-Diesel-Str. 24-28  
69168 Wiesloch-Baiertal  
Germany

Tel: +49 (0)6222-9800-0  
Fax: +49 (0)6222-9800-50  
E-Mail: [info@engelmann.de](mailto:info@engelmann.de)  
[www.engelmann.de](http://www.engelmann.de)